



[A COMPANY CONTINUALLY
EVOLVING.]



A "continuing evolution" best describes the development of ZMC.

From the original ideas of the founders, Angelo Zibetti, Mario Mattiolo and Angelo Croci, in 1954, the company has evolved new ideas and manufacturing processes that continue to drive the company forward.

This continuing evolution of modern manufacturing techniques and ideas, has seen ZMC acknowledged both

in Italy and across the International industrial market as one of the most advanced conveyor chain manufacturers in the world. The Factory, in Cavaria, Italy, is one of the largest and most up to date chain production facilities in Europe. Employing more than 150 skilled workers, with an expanding production area of 150 000 square metres and monthly outputs exceeding 100 000 metres of chain. "The evolution continues."

EVOLUTION



QUALITY

ZMC is a solid, modern organised company that is continually evolving. The planning procedures and production processes assure **quality** and consistency across the whole product range. The vast stock of

semi-finished and finished chains, the technical back up of a large commercial organisation along with experienced, technically qualified agents

throughout Europe and the World, ensures a quality and service that is second to none.

The combination of these factors makes ZMC a company that is dedicated to 'customer satisfaction'.



es
un
is
un
es

ENGINEERING DATA



CHAIN SELECTION - GENERAL CONSIDERATION

In order to ensure a correct approach to the selection of conveyor chains, the following points should be considered:

- 1) TYPE OF CONVEYOR
- 2) TOTAL LOAD TO BE CARRIED
- 3) CHAIN SPEED
- 4) CHAIN PITCH
- 5) TYPE OF ATTACHMENT
- 6) OPERATING CONDITIONS
- 7) LUBRICATION
- 8) CHAIN BREAKING LOAD

1) TYPE OF CONVEYOR

Conveyor chains are classified in two categories:

- a) bush chains,
- b) roller chains.

These two categories are further subdivided into conveyors that are:

- a) horizontal,
- b) inclined,
- c) vertical,
- d) combination.

2) TOTAL LOAD TO BE CARRIED

This is the weight of the carried material on the conveyor chain plus the weight of any attachments and / or carriers (i.e. slats, swing trays, crossbars, fasteners, etc.).

It is essential that the load distribution is considered since the calculation factors for concentrated loads on a limited support surface are different from those for a uniformly distributed load.

3) CHAIN SPEED

The chain speed, the distance travelled by the chain in a given unit of time, is a fundamental factor in determining the conveyor capacity. It is from this parameter that chain pitch and the diameter of the drive and driven wheels is derived.

Fig. 1 illustrates this relationship.

$$V = \frac{P \cdot Z \cdot n}{1000} \quad [\text{m/min}]$$

P = chain pitch [mm]

Z = number of teeth

n = revolution per minute of the wheel [rpm]

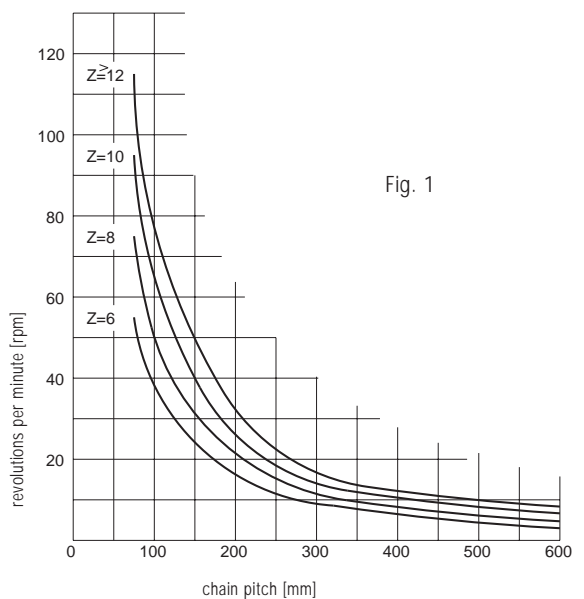

Fig. 1



The maximum recommended speed for conveyor chains is 60 metres per minute with an ideal speed range between 0 and 30 m/min.

Chain speed contributes greatly towards the condition known as **Hunting or Surging**.

Hunting (or Surging) is defined by irregular chain speed, a series of fast and slow chain surges. This condition can seriously compromise the functionality of a chain conveyor, the main factors that can contribute to this effect are outlined in the following:

- The polygonal effect, due to the gearing of the chain with sprockets, (shown in in Fig. 2) can cause a small amount of chain surge. This can be more marked on long pitch chain with number of teeth below 8.
- Cumulative effect of friction along the length of the conveyor (on the drive and return strands): intermittent contact between the chain side plates and the track guides can cause the chain to surge.
- 'Stick slip' is a condition that can occur on slow running conveyors. It is often caused by over lubrication of the chain. The over lubrication floods the chain track with oil or grease and lowers the rolling friction between the chain roller and the track. Once this rolling friction becomes less than that of the rolling friction between the chain bush and the roller bore, the roller stops turning. The lubricant then builds up at the pressure face between the bush and the roller bore creating a vacuum between the two surfaces. With the chain track flooded with oil there is no available friction to turn the roller until the conveyor is stopped or the chain roller to track friction increases. This condition of skidding rollers and rotating rollers can cause the chain speed to fluctuate up and down. Stick slip conditions are more prevalent on lightly loaded conveyors as heavier loads will break the lubrication film on the chain track.
- Uneven loading of the conveyor, along its length, can also contribute towards the stick slip condition.
- On longer conveyors of 80 - 100 metres other factors must be taken into consideration, such as cumulative pitch tolerance.

Hunting / Surging of conveyors maybe eliminated by reducing the rolling friction of the chain. This can be achieved by the use of low friction bushings in the roller bore or by introducing a bearing element into the roller / bush interface / as an alternative, twin track integral ball bearings can be introduced. The additional advantage of this method is the overall reduction of the coefficient of friction of the conveyor. This reduction can have a major influence on the selection of head shaft diameters and motor / gearbox sizes.

For further technical details please contact our technical department.

The following graph shows the speed variation due to the polygonal effect (%).

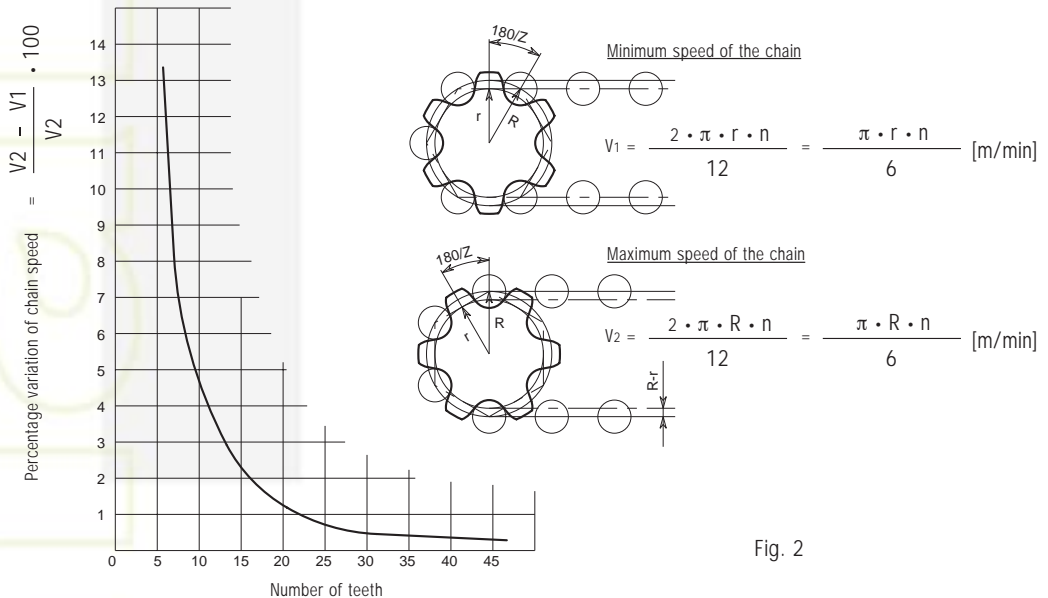

Fig. 2

- n = rpm
- Z = number of teeth of the wheel
- R = pitch radius of the wheel [mm]

$$r = R \cdot \cos \frac{180^\circ}{Z} \text{ [m]}$$

R-r = range of variation of the polygonal effect [mm]



4) CHAIN PITCH

This is the distance expressed in millimetres or inches between two consecutive pin centres of the chain and is determined by the following conveyor characteristics:

- chain speed
- diameter of drive and driven wheels
- conveyor load distribution
- spacing of attachments / carriers (i.e. slats, swing trays, crossbars, fasteners, etc).

5) CHAIN ATTACHMENTS

Slats / carriers are attached to the chain by means of angle iron sections welded to the chain plates or they may be extensions of the chain plates. Chain attachments are defined by the dimensions, shape, number per linear metre, and the type of material to be conveyed.

6) OPERATING CONDITIONS

The environment in which the conveyor chain is to operate has an enormous influence on its design. The choice of material, quality of materials, tolerances, production methods, anti corrosion treatments and safety factors are all dependent on the following:

- degree of cleanliness
- operating temperature
- presence of abrasive substances
- humidity / atmospheric substances
- presence of aggressive chemical substances
- etc.

Knowledge of the operating temperature is particularly important since it affects the breaking load of the chain as demonstrated in Table 1:

TABLE 1

TEMPERATURE	ADJUSTED WORK LOAD
-40° C ~ -20° C	(Maximum allowable work load) x 0,25
-20° C ~ -10° C	(Maximum allowable work load) x 0,30
-10° C ~ 160° C	(Maximum allowable work load) x 1,00
160° C ~ 200° C	(Maximum allowable work load) x 0,75
200° C ~ 300° C	(Maximum allowable work load) x 0,50

For further information on other operational conditions, contact our Technical Office.

7) LUBRICATION

Lubrication of the conveyor chain is essential since it reduces wear and prevents corrosion and oxidation.

It also determines the friction factors and hence the chain pull.

See page 1.6.2 for more information on product, quality and usage.

8) BREAKING LOAD

Expressed in Newton's this is the value given to the point at which the chain will fail in tensile pull.

The data given in the catalogue is based on tensile pull tests at ambient temperature.

The breaking loads given are an average value based on a number of tests.

The range variation, from average, should be considered as no more than 5%.



CHAIN SELECTION - CHAIN PULL

Chain pull is that force required to move the chain, the connected mechanical parts and the load to be conveyed.
The chain pull required for a particular application is dependent on the following factors:

- 1) WEIGHT OF MATERIAL CARRIED
- 2) WEIGHT OF CHAINS AND SUPPORT ELEMENTS (SLATS, SWING TRAYS, CROSSBARS, FASTENERS, ETC.)
- 3) COEFFICIENT OF FRICTION
- 4) SERVICE FACTOR
- 5) GEARING FACTOR

The calculation of chain pull is carried out in two phases:

- the preliminary phase, a calculation which determines the type of chain required by the chain weight and the coefficient of friction.
- the second phase, a control calculation, confirms the preliminary chain weight and coefficient of friction by substituting actual values of the identified chain.

1) WEIGHT OF MATERIAL CARRIED = P1 [kg]

See paragraph 2 of the chapter "Chain selection – General considerations".

2) WEIGHT OF CHAINS = P [kg]

For the preliminary calculations this is the approximate weight of the entire chain circuit including any attachments (slats, swing trays, crossbars, fasteners, etc.). For the control calculation it is the actual weight of the entire chain circuit.

3) COEFFICIENT OF FRICTION

The coefficient of friction is the value that defines the force necessary to overcome resistance to movement when two bodies are in contact. When operating in a "sliding" mode along a track, chains must overcome sliding friction "fr". Typical values for sliding friction coefficients are outlined in the following table.

TABLE 2

BODIES IN CONTACT	fr dry surface	fr lubr. surface
Steel chains on hardwood tracks	0,44	0,29
Steel chains on steel tracks	0,30	0,20
Steel chains on rough or rusty tracks	0,35	0,25
Steel chains on tracks of high density very high molecular weight polyethylene	0,18	0,05

When running on rollers chains must overcome both sliding and rolling friction "fv".

The value of the rolling coefficient in the preliminary calculation is assumed to be $f_v = 0,2$, whilst in the control calculation its value is given as:

$$f_v = C \cdot \frac{d}{D} + \frac{b}{D}$$

where

d = bush outside diameter [mm]

D = Roller outside diameter [mm] see catalogue.

b = Coefficient dependent on the type of materials used and the grade of machined surfaces.

= 1 · for steel roller on steel track with smooth surface

= 2 · for steel roller on steel track with rough surface

C = the sliding friction coefficient between bush and roller, outlined in the following table.



TABLE 3

BODIES IN CONTACT	Dry surface "C"	Lubricated surface "C"
Steel roller on steel bush	0,25	0,15
Roller with bronze bush on steel bush	N/A	0,13
Nylon roller on steel bush	0,15	0,10

Important

It is important to note that in the initial stage of movement, the starting friction coefficient can be 1.5 to 3 times greater than the dynamic friction coefficient.

As a general guide, in order to minimise initial friction, the external diameter of the roller should be at least 2.5 times greater than the external diameter of the bush.

4) SERVICE FACTOR = FS

Chain pull must be multiplied by an adjustment coefficient (FS) to take account of operational conditions and characteristics of the conveyors. FS values for the most common applications are outlined in the following table.

TABLE 4

OPERATING CONDITIONS	FS
Load position	
- Centred	1
- Not centred	1,2
Load characteristics	
- Uniform: extent of overloading less than 5%	1
- With minor variations: extent of overloading 5 to 20%	1,2
- With major variations: extent of overloading 20 to 40%	1,5
Frequency of loaded starting/stopping	
- Less than 5 per day	1
- From 5 per day to 2 per hour	1,2
- More than 2 per hour	1,5
Working environment	
- Relatively clean	1
- Quite dusty or dirty	1,2
- Humid, very dirty or corrosive	1,3
Number of hours in use daily	
- Up to 10	1
- More than 10	1,2

To obtain the total FS coefficient, (FS) value for each operational condition must be multiplied together.

5) GEARING FACTOR = FA

This is an adjustment coefficient made to the chain pull, which increases due to the additional friction caused by the rotation of the chain on the drive and driven wheels.

FA = 1,05 for wheels mounted on brass bushes
 = 1,03 for wheels mounted on bearings

The sum of all products obtained by multiplying FA for the chain pull in each gearing point determines the new total chain pull. For the following examples the "FA" values will not be considered.

CHAIN PULL CALCULATIONS

a) Horizontal conveyor with sliding chains

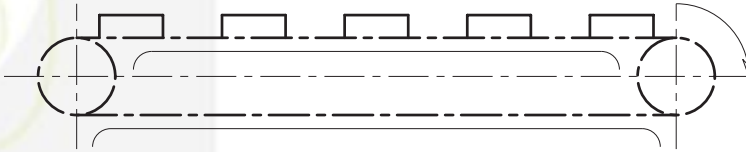

Fig. 3

$$T = 9,81 \frac{(P+P1) \cdot fr \cdot FS}{\text{No. of chains}} \text{ [N]}$$

b) Horizontal conveyor with roller chains

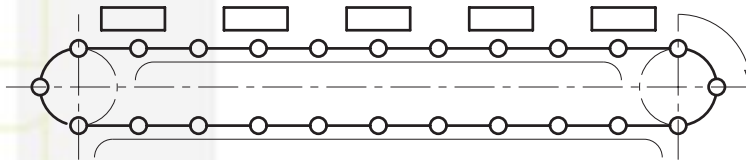

Fig. 4

$$T = 9,81 \frac{(P+P1) \cdot fv \cdot FS}{\text{No. of chains}} \text{ [N]}$$

c) Inclined conveyor with sliding chains

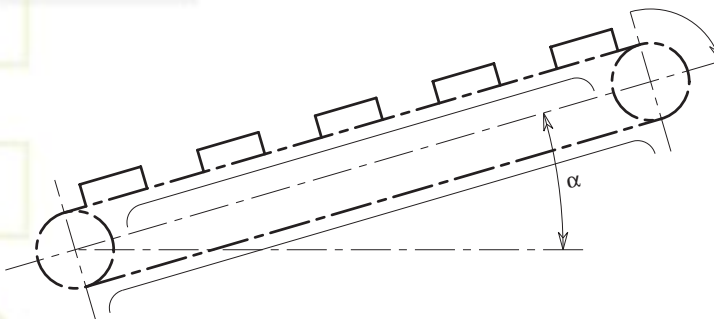

Fig. 5

$$T = 9,81 \frac{[\cos\alpha (P+P1) \cdot fr + \sin\alpha \cdot P1] \cdot FS}{\text{No. of chains}} \text{ [N]}$$

d) Inclined conveyor with roller chains

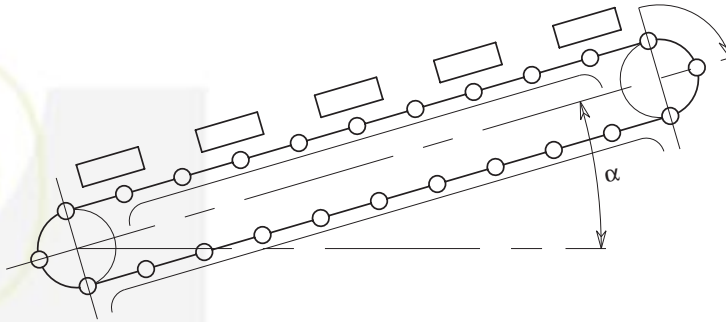

Fig. 6

$$T = 9,81 \frac{[\cos\alpha (P+P1) \cdot f_v + \sin\alpha \cdot P1] \cdot FS}{\text{No. of chains}} \text{ [N]}$$

e) Vertical elevator

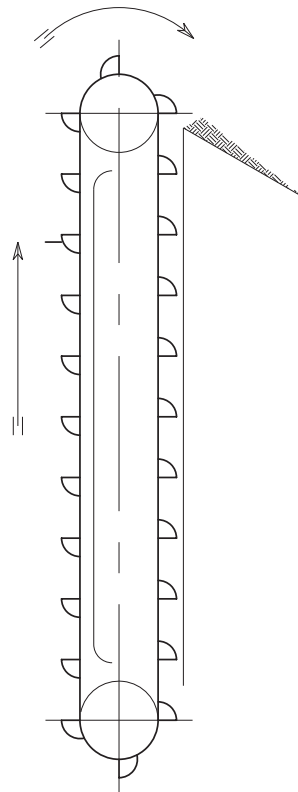

Fig. 7

$$T = 9,81 \frac{(P/2+P) \cdot FS}{\text{No. of chains}} \text{ [N]}$$

N.B.:

For further technical assistance on vertical conveyors not covered in this catalogue, please contact our technical office.



SCRAPER CONVEYORS

To calculate the chain pull of scraper conveyors, additional parameters need to be considered:

f_m	=	coefficient of friction between material to be moved and the side guides (table 5),
L	=	portion of loaded conveyor [m],
Q	=	mass of product to be transported [T/h],
H	=	height of side guide [m],
B	=	width between guides [m],
β	=	product depth normally not exceed 50-60 % of H ,
γ	=	specific weight of material conveyed. [T/m ³] (table 5),
v	=	chain speed. [m/sec].

TABLE 5

MATERIAL CONVEYED	Spec. weight γ . [T/m ³]	Friction coefficient f_m
Oats	0,45	0,7
Wheat	0,75	0,4
Corn	0,8	0,4
Dried barley	0,45	0,7
Rye	0,65	0,4
Rice	0,75	0,4
Linseed	0,7	0,4
Dried malt	0,4	0,4
Wheat flour	0,7	0,4
Corn flour	0,65	0,4
Refined powdered sugar	0,8	0,5
Cement	1,00	0,9
Anthracite coal in pieces	0,7 to 0,9	0,4
Coking coal	0,5	0,7
Dried clay	1,6	0,7
Ashes	0,6	0,6
KLINKER cement gravel	1,3	0,8

** indicative values

a) Horizontal conveyor with sliding chains and material

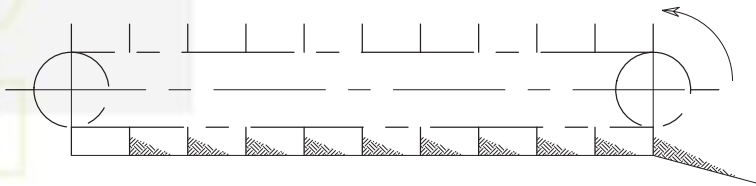

Fig. 8

$$T = 9,81 \frac{[(P \cdot f_r + P1 \cdot f_m) \cdot FS]}{\text{No. of chains}} \text{ [N]}$$

Where P1 can be calculated as follows:

a) $P1 = H \cdot B \cdot L \cdot \beta \cdot \gamma \cdot 1000 \text{ [kg]}$

b) $P1 = \frac{L \cdot Q}{3,6 \cdot v} \text{ [kg]}$

If Q is unknown it can be calculated as follows: $Q = H \cdot B \cdot \beta \cdot \gamma \cdot v \cdot 3600 \text{ [T/h]}$



b) Horizontal conveyor with roller chains and scraper bars

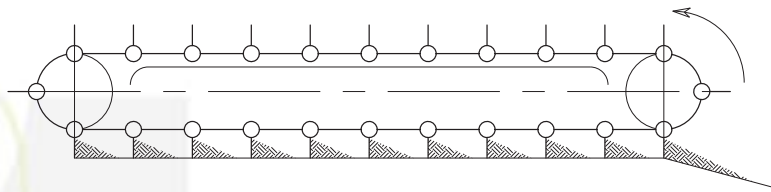

Fig. 9

$$T = 9,81 \frac{[(P \cdot fr + P1 \cdot fm) \cdot FS]}{\text{No. of chains}} \text{ [N]}$$

Where P1 can be calculated as follows:

a) $P1 = H \cdot B \cdot L \cdot \beta \cdot \gamma \cdot 1000 \text{ [kg]}$

b) $P1 = \frac{L \cdot Q}{3,6 \cdot v} \text{ [kg]}$

If Q is unknown it can be calculated as follows: $Q = H \cdot B \cdot \beta \cdot \gamma \cdot v \cdot 3600 \text{ [T/h]}$

DETERMINING THE TYPE OF CHAIN TO USE

Having established the maximum chain pull, the maximum stress that chain components will be subjected to must then be considered.

It is generally accepted that a chain, working at 65% of the breaking load will be stressed beyond the 'elastic limit' of the side plate material.

In order to provide a sufficient margin of safety, the chain breaking load should therefore be at least 8 times the maximum working load.

This safety margin is known as the factor of safety.

It is essential that an adequate safety factor is provided and in cases where variations in chain pull values are difficult to quantify, the Technical Office should be consulted.

In situations where high density loads are moved on small conveyor surface, the calculation of chain pull alone is not always sufficient to identify chain type.

In these instances, the specific pressure values between the rollers/bushes and bushes/pins should also be considered.

If the specific pressure values exceed those listed in table 6-7, then a chain with greater contact surface between the rollers and bushes, or bushes and pins must be considered.

Calculation of bearing pressure

a) roller loading = $\frac{P}{L \cdot Dr} \left[\frac{\text{kgf}}{\text{mm}^2} \right]$

b) pin pressure = $\frac{T}{Lb \cdot Dp} \left[\frac{\text{kgf}}{\text{mm}^2} \right]$

where:

- P = load [kgf] supported by each roller
- T = chain pull [kgf]
- L = distance through roller bore [mm]
- Lb = total bush length [mm]
- Dr = diameter of roller bore [mm]
- Dp = external diameter of pin [mm]



MAXIMUM ALLOWABLE PRESSURES

TABLE 6

MATERIALS IN CONTACT		Max. spec. Press. Kgf/mm ²
BUSH	PIN	
Case-hardened steel	Case-hardened steel	2,5
Case-hardened steel	Hardened-tempered steel	2,1
Cast iron	Case-hardened steel	1,75
Stainless steel	Stainless steel	1,2
Bronze	Case-hardened steel	1

TABLE 7

MATERIALS IN CONTACT		Max. spec. Press. Kgf/mm ²
ROLLER	BUSH	
Case-hardened steel	Case-hardened steel	1
Hardened-tempered steel	Case-hardened steel	1
Cast iron	Case-hardened steel	0,70
Bronze	Case-hardened steel	0,60
Polyethylene A.D.	Case-hardened steel	0,1
Stainless steel	Stainless steel	0,40
Cast iron	Bronze	0,28

CALCULATION OF POWER REQUIRED AT HEAD SHAFT

Once the conveyor's total chain pull has been determined, the following procedure for the calculation of shaft power requirements should be used:

$$M_t = \frac{T \cdot dp}{2} \text{ [kgm]} \quad M_t = 716,2 \cdot \frac{N}{n} \text{ [kgm]}$$

where:

- M_t = torque [kg m]
- N = power [CV, Hp or KW]
- n = head shaft rpm
- T = total chain pull [kg]
- dp = PCD of the drive sprockets [m]

From these two relationships it is concluded that:

$$\frac{T \cdot dp}{2} = 716,2 \cdot \frac{N}{n}$$

From which is derived

$$N = \frac{T \cdot dp \cdot n}{2 \cdot 716,2} \text{ [CV]}$$

or

$$N = \frac{T \cdot dp \cdot n}{2 \cdot 973,8} \text{ [KW]}$$

The usable power output of the motor must be determined taking into account losses from reduction devices, belts, etc.



LUBRICATION OF CHAINS

Chain lubrication is essential for the following reasons:

- 1) REDUCTION IN THE COEFFICIENT OF FRICTION
- 2) REDUCING CHAIN WEAR AND SAVING ENERGY
- 3) PREVENTION OF CORROSION
- 4) CORRECT FUNCTIONING OF THE CHAIN

1) REDUCTION IN THE COEFFICIENT OF FRICTION

Friction is defined as the mechanical resistance produced between two surfaces in motion against each other.

There are two basic types of Friction, Static and Dynamic.

Static friction R_s is the resistance given by a surface to relative movement when an external force is applied.

It can also be known as the breakaway friction. Experience shows that to obtain movement of a body of weight P rested on a plane, the force necessary to move that body, F , is a product of the coefficient of static friction, μ and the weight of the body P .

Dynamic friction is the resistance given by a body already in motion, that is the resistance given to an external force exerted to overcome the friction between two surfaces. The force required to keep a body in motion is always less than that to move a body from rest.

Dynamic friction R_d is a product of the coefficient of dynamic friction f and the weight of the body P .

$$R_s = P \cdot \mu \text{ (Kg)}$$

$$R_d = P \cdot f \text{ (Kg)}$$

The value of both μ the coefficient of static friction and f the coefficient of dynamic friction are dependant on the quality of the surfaces in contact, the type of contact (sliding or rolling), the relative speeds between the surfaces and the presence of lubrication.

Fig. 10 shows the influence of relative speed on the coefficient of friction. The curve is divided in three parts:

- part 1 shows friction at very slow speed, in this case the film of lubricant between the two surfaces is not thick enough to prevent contact;
- part 2 is an intermediate condition;
- part 3 shows friction at higher speed when the film of lubricant is thick enough to ensure that motion takes place without direct contact between the two surfaces.

Fig. 10

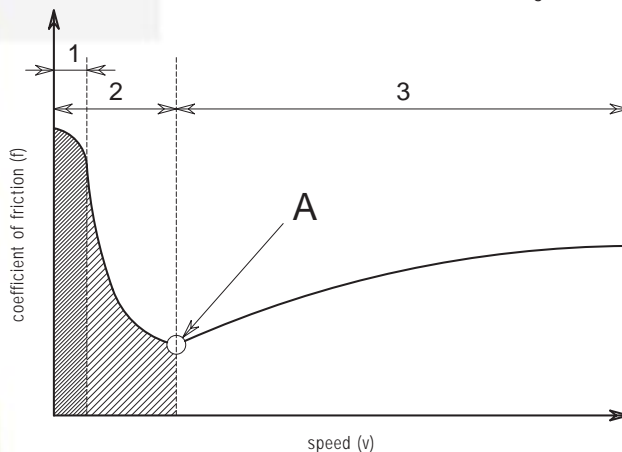

2) REDUCING CHAIN WEAR AND SAVING ENERGY

The absence of a lubricant film causes the rotating parts of the chain to come into direct contact with each other. This in turn causes progressive wear of the mating surfaces, which results in premature failure of the chain. Additional friction caused by premature wear results in an increase in chain pull, requiring a higher power input from the motor, using more energy. The presence of a lubricant prevents metal to metal contact, increases the operating life of the chain and saves a considerable amount of energy.

Figure 11 shows the percentage elongation of a chain, based on working hours and type of lubrication.

Key.

- Percentage elongation of chains working with no pre lubrication or running lubrication.
- Percentage elongation with pre lubrication but no further working lubrication.
- Chain with pre lubrication and then only sporadic re lubrication.

This clearly shows that the lubrication periods are set at too great a time. Wear therefore occurs on a cyclic periods.

- This curve indicates the unsuitability of lubricant used or the under lubrication of the chain.
- Optimum lubrication.

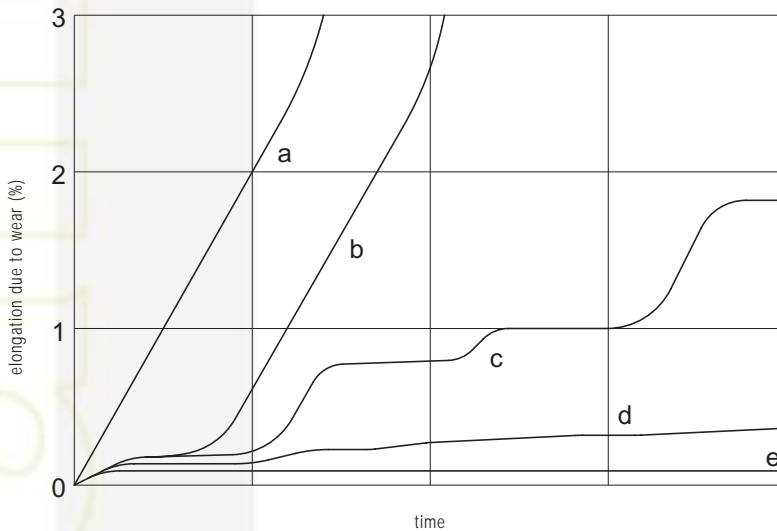

Fig. 11

3) PREVENTION OF CORROSION

Any non-protected metal is subject to oxidation.

This phenomenon is exacerbated by environmental conditions, such as:

- high temperatures
- high humidity
- presence of aggressive chemical substances

Oxidation or corrosion is a serious threat to chain life.

The presence of a lubricant film on the surface of the chain's components, creating a barrier between the chain and the external environment, prevents the formation of oxides and the onset of corrosion.

The effectiveness of this protection can be improved by the addition of corrosion inhibitors within the lubricant.



4) CORRECT FUNCTIONING OF THE CHAIN

Adequate lubrication ensures continuous functioning of the chain and has the additional advantage of reducing operating noise.

CHOICE OF LUBRICANT

It is impossible to prescribe one lubricant for all applications. Many parameters determine the choice of lubricant; but the most important one is operating temperature.

For practical purpose, operating temperature can be sub-divided as follows:

- a) Low temperature - - 40°C to 15°C
- b) Normal temperature - 15°C to 110°C
- c) High temperature - 110°C to 250°C
- d) Very high temperature - more than 250°C

A) LOW TEMPERATURE (- 40° C TO 15° C)

When operating temperatures fall below 0 degrees it is necessary to select the correct lubricant to keep the chain in good condition. In very low operating temperatures synthetic oils, with low viscosities are often used. In applications that require no oil contamination or fling off into the surrounding area it is best to apply greases in dispersions that will carry the grease into the round parts of the chain and then dry to allow little or no dripping or fling off. For low temperature conditions we would recommend KLÜBERSYNTH UH14-68N or ISOFLEX grease NBU 15. We do suggest that a lubrication company be contacted to get first hand technical knowledge before a final decision is taken on which lubricant is used.

B) NORMAL TEMPERATURE (+ 15° C TO 110° C WITH POINTS UP TO 150° C)

The use of mineral oils is not recommended; specific lubricants for chains with additives to prevent dripping and improve capillarity are more appropriate. One product which meets these requirements is the grease fluid STRUCTOVIS FHD (KLÜBER LUBRICATION), which has an excellent adhesive capacity to minimise dripping and low surface tension which permits "sapping" of any drops of moisture which may be present on the metallic surface. These attributes ensure maximum lubrication even in the most difficult conditions.

C) HIGH TEMPERATURE (FROM 110° C TO 250° C)

The use of synthetic oils is necessary in this temperature range because their thermal stability is superior to that of mineral oils. Oils containing combinations of solid pigments with a graphite or molybdenum disulphide base are recommended because they provide emergency lubrication and increase the maximum specific pressure value. Additionally these oils contain additives to prevent the formation of sludge. The synthetic oil SYNTHESCO (KLÜBER LUBRICATION) is recommended since it has less tendency to smoke (NON-toxic).

D) VERY HIGH TEMPERATURES

In these temperature conditions, a fluid lubricant is ineffective. A solid lubricant suspended in a synthetic "vehicle" should be used. The synthetic solution evaporates and leaves the lubrication place. A certain quantity of smoke generation is inevitable in this case. The application must be carried out when the chain is cold. WOLFRAKOTE TOP FLUID S (KLUBER LUBRICATION) is recommended.

CLEANING OF CHAINS

The cleaning of chains and tracks along with the correct lubrication of the chain can give vastly improved chain life. In certain conditions re lubrication of a chain without first cleaning the chain and tracks can be detrimental to the running of the conveyor, and will render re lubrication completely ineffectual.

It is recommended that chains be cleaned in the following circumstances:

- Before periods of extended downtime. It is advisable to clean the chains before applying a suitable protective product.
- When the chains reach a point that they are so contaminated that the dirt build up cannot be removed by normal methods.



(i.e. flushing with lubricant, brushing or washing down.) At this point it is recommended that the chain be removed from the conveyor thoroughly cleaned, dipped in a lubricant bath, and allowed to soak for at least 6 hours, before being put back on the conveyor.

- If a reaction takes place between the grease used by the manufacturer and the product used for re lubrication the chains must be removed from the system, degreased and re lubricated before being put back into service.

NOTE.

When washing chains with water or water/detergent mix products it is essential that the chains are re-lubricated with a product that will displace moisture and penetrate into the round parts.

Suggested procedure for cleaning chains.

- 1) Remove chain from conveyor.
- 2) Remove all surface dirt and oil/grease, with rags or brushes
- 3) Wash the chain with a solvent/lubricant mix. Paying attention to remove all contamination from the round parts.
(i.e. ensure all round parts rotate freely and all links articulate.)
- 4) Immerse the cleaned chain in a suitable lubricant bath for a minimum of 6 hours.

INITIAL LUBRICATION

For the initial lubrication of the chains the special lubricant STRUCTOVIS FHD of KLÜBER LUBRICATION is used.

The viscous structure of this chain oil distinguishes itself clearly from traditional chain lubricants by the following characteristics:

- high adhesion (anti drop)
- water-repellent
- very good wear protection
- excellent ageing stability
- very good temperature stability up to 150°C

STRUCTOVIS FHD - Chemical physical properties		
Density at 20°C [g/cm³]	DIN 51757	Approx. 0,890
Kinematic viscosity [mm²/sec]	DIN 51561	
	at 40° C	145
	at 50° C	86
	at 100° C	15
Viscosity index	ISO 2909	100
Flash point (°C)	DIN 51376	>250
Pourpoint (°C)	DIN ISO 3016	-12

Since 1979, KLÜBER Lubrication Italia has been subsidiary of the German company KLÜBER Lubrication München KG, which is represented world-wide through 14 productions plants and more than 50 sales offices.

Thanks to a large choice of special lubricants, KLÜBER Lubrication Italia offers solutions for all requirements of lubrication.

KLÜBER Lubrication Italia has the DIN ISO 9002 and DIN ISO 14001 certificates and the EC eco-audit validations EMAS.

KLÜBER Lubricants are also available throughout Europe.

KLÜBER Lubrication Italia s.a.s.

Via Monferrato, 57

20098 S.Giuliano Milanese (MI)

Tel. 02-98213.1 - Fax 02-98.28.15.95

klita@klueber.com



LUBRICATION SYSTEM

Automatic lubricant distribution is always recommended, because it ensures optimum lubricant dosage. This avoids accidental dry operation and prevents over-lubrication and consequent dripping. The lubricant, whether sprayed or atomized, must reach the flanks of the rollers and between the plates of the pins to ensure an even distribution to all parts of chain. Provided a suitable lubricant is used, it is not necessary for the chain to be soaked, merely dampened. Lubrication frequencies or quantities cannot be given here, every case should be individually assessed.

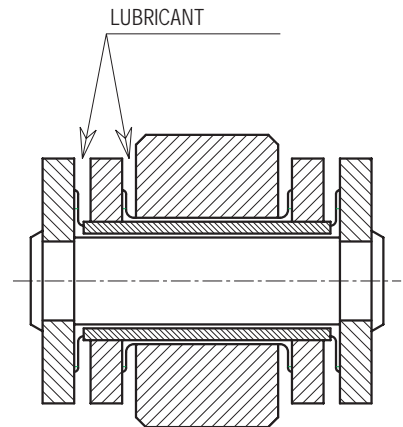

CONCLUSION

The lubrication discussion is by no means exhaustive, and is offered merely as a method of highlighting the importance of the correct lubrication of moving parts. Regretably, this subject is often either ignored or underestimated, but to ensure chain longevity, smooth and quiet running at minimum power consumption, it is crucial.

CHAIN IDENTIFICATION

To avoid misinterpretation, a standard terminology for chain identification is proposed. To demonstrate this terminology, the type of chain and the type of attachment are considered separately.

TYPE OF CHAIN

a) Each chain type is assigned a number, which identifies all the chain characteristics such as: pitch, internal width, roller diameter, etc.

Example:

Chain No. 352 - No. C2080H - No. 400C

b) The series not unified in inches DIN 8167 and series DIN 8165 chains are additionally identified by a letter (A) for the bush solution, (B) for the small roller, (C) for the large roller, or (D) for the flange roller and by a number which specifies chain pitch. (A single chain type can be almost any pitch).

Examples:

a) chain No. Z40-A-101,6

means:

Z40	=	solid-pin chains, series BS 4116
A	=	bush chain
101,6	=	pitch of 101,6 mm.

b) chain No. MC112-D-200

means:

MC112	=	chain with hollow pins, series DIN 8167
D	=	flange roller
200	=	pitch of 200 mm



c) Special chains not listed in the catalogue, are classified by pitch, internal width, roller diameter and the relevant design number.

Example:

chain pitch 150 X 23 X 45 in design n. 001954

Any deviation from the production standard must be followed by precisely defined characteristics.

Examples:

- a) chain N° 500 zinc-plated
- b) chain N° 500 with hardened and tempered plates
- c) chain N° 500 with 20 mm diameter rollers

TYPE OF ATTACHMENT

Attachments are defined by dimensional characteristics from a standard table or, in the case of special attachments, by a precisely detailed drawing.

The chain identifying code also includes the attachment code and specifies how the attachment is to be put into position, how many holes it must have, etc. as follows:

- A = for single-sided bent attachment
- M = for single-sided vertical attachment
- K = for double-sided bent attachment
- MK = for double-sided vertical attachment
- 1 = for single-holed attachment
- 2 = for double-holed attachment
- 3 = for triple-holed attachment
- 01 = for attachment every pitch
- 02 = for attachment every 2 pitches
- 10 = for attachment every 10 pitches
- 0X = for attachment every X pitches

Examples:

- a) chain No. 500A202
means:
chains type 500 single-sided attachments, with two holes, every 2 pitches
- b) chain No. 703K304
means:
chain type 703, double-sided attachments, with 3 holes, every 4 pitches
- c) chain No. M160C125A203
means:
chain series M ..., single-sided attachments, with 2 holes, every 3 pitches

Special attachments, or those which depart from the catalogue norm, are identified with the same classification criteria, but must always include the drawing number:

Example:

Chain No. 704A1-01, drawing N° 001988

When the attachments are required at even pitch intervals (02-04-06 etc.), they will be assembled on the external link of the chain unless otherwise specified.

The following pages illustrate the most common attachment assembly combinations.

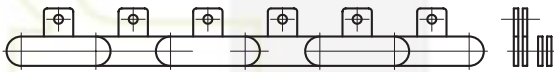

M1-01

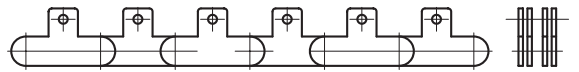

MK1-01

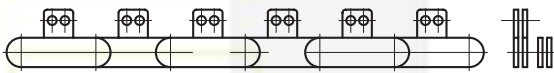

M2-01

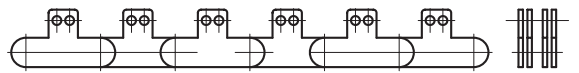

MK2-01

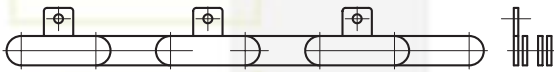

M1-02

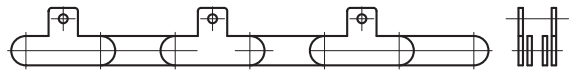

MK1-02

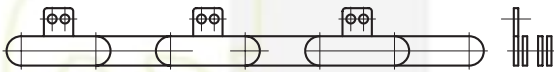

M2-02



MK2-02

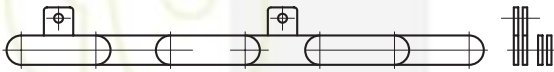

M1-03

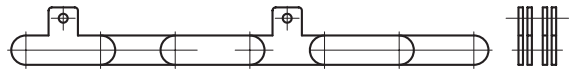

MK1-03

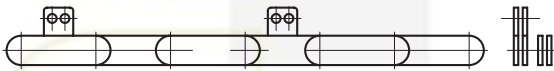

M2-03

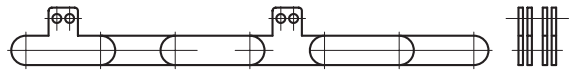

MK2-03



M1-04

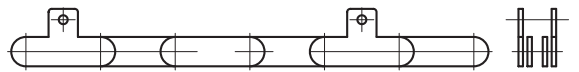

MK1-04



M2-04

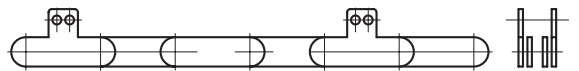

MK2-04



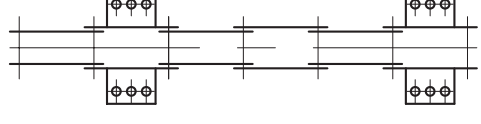
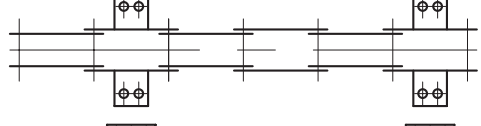
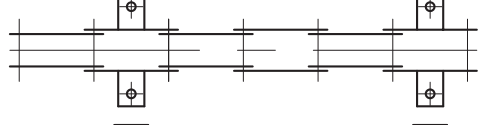
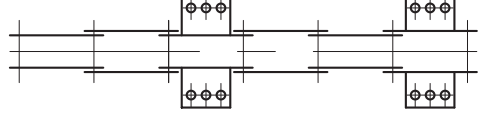
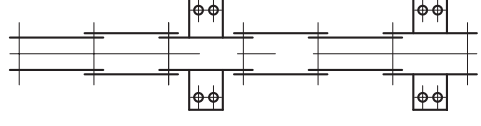
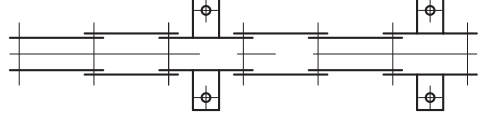
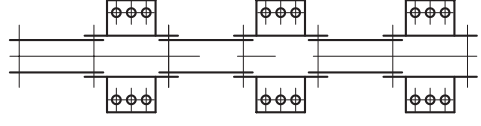
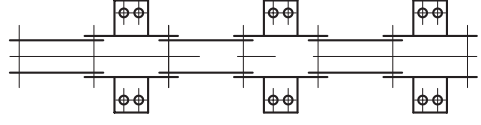
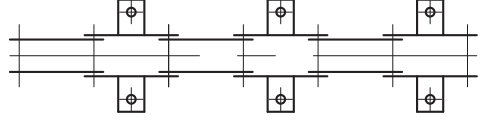
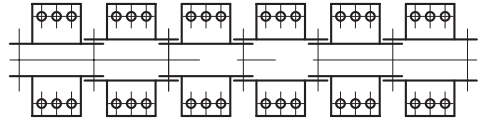
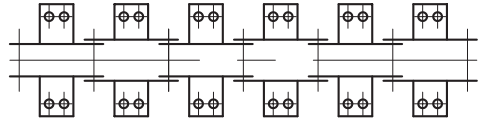
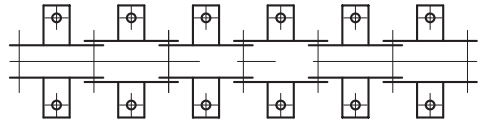
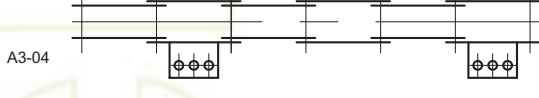
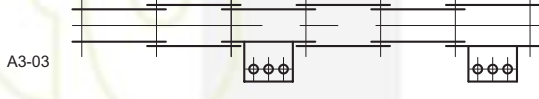
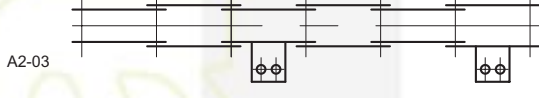
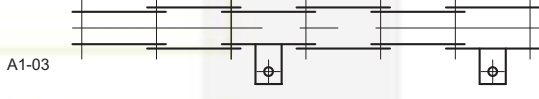
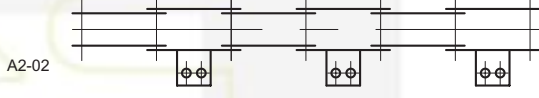
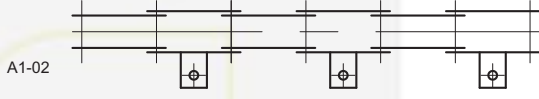
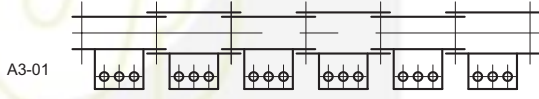
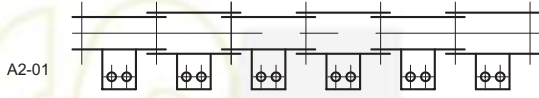
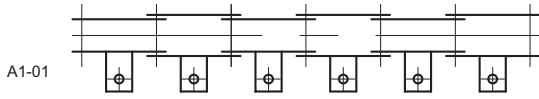

K1-01

K2-01

K3-01

K1-02

K2-02

K3-02

K1-03

K2-03

K3-03

K1-04

K2-04

K3-04



CONVERSION FACTORS

Measure	LENGTH	multiplying by	to obtain	Measure
m	metre	39,3701	inch	in
m	metre	3,28084	foot	ft
m	metre	1,09361	yard	yd
cm	centimetre	0,393701	inch	in
cm	centimetre	0,032808	foot	ft
mm	millimetre	0,039370	inch	in
mm	millimetre	0,003280	foot	ft
in	inch	25,4	millimetre	mm
in	inch	2,54	centimetre	cm
in	inch	0,0254	metre	m
ft	foot	304,8	millimetre	mm
ft	foot	30,48	centimetre	cm
ft	foot	0,3048	metre	m
mi	mile	1,60934	kilometre	km
mi	mile	1609,344	metre	m
km	kilometre	0,621371	mile	mi
Measure	AREA	multiplying by	to obtain	Measure
m ²	square metre	1550	square inch	in ²
m ²	square metre	10,7639	square foot	ft ²
m ²	square metre	1,19599	yard square	yd ²
cm ²	square centimetre	0,001076	square foot	ft ²
cm ²	square centimetre	0,155	square inch	in ²
mm ²	square millimetre	0,00155	square inch	in ²
mm ²	square millimetre	0,000010 (1,07639x10 ⁻⁵)	square foot	ft ²
in ²	square inch	0,000645 (6,64516x10 ⁻⁴)	square metre	m ²
in ²	square inch	6,4516	square centimetre	cm ²
in ²	square inch	645,16	square millimetre	mm ²
ft ²	square foot	0,092903	square metre	m ²
ft ²	square foot	929,03	square centimetre	cm ²
ft ²	square foot	92903	square millimetre	mm ²
Measure	VOLUME	multiplying by	to obtain	Measure
m ³	cubic metre	61023,7	cubic inch	in ³
m ³	cubic metre	35,3147	cubic foot	ft ³
m ³	cubic metre	219,969	UK gallon (imperial)	UK gallon
m ³	cubic metre	264,172	USA gallon	gal (U.S. liquid)
l (dm ³)	litre	61,0237	cubic inch	in ³
l (dm ³)	litre	0,035314	cubic foot	ft ³
l (dm ³)	litre	0,219969	UK gallon (imperial)	UK gallon
l (dm ³)	litre	0,264172	USA gallon	gal (U.S. liquid)
cm ³	cubic centimetre	0,061023	cubic inch	in ³
cm ³	cubic centimetre	0,000035 (3,53147x10 ⁻⁵)	cubic foot	ft ³
ft ³	cubic foot	0,028316	cubic metre	m ³
ft ³	cubic foot	28,3168	litre	l (dm ³)
ft ³	cubic foot	28316,8	cubic centimetre	cm ³
in ³	cubic inch	0,000016 (1,63871x10 ⁻⁵)	cubic metre	m ³
in ³	cubic inch	0,016387	litre	l (dm ³)
in ³	cubic inch	16,3871	cubic centimetre	cm ³
UK gallon	UK gallon (imperial)	0,004546	cubic metre	m ³
UK gallon	UK gallon (imperial)	4,54609	litre	l (dm ³)
Measure	ANGLES	multiplying by	to obtain	Measure
°	degree (angle)	0,017453	radian	rad
rad	radian	57,2958	degree (angle)	°



CONVERSION FACTORS

Measure	TORQUE	multiplying by	to obtain	Measure
N m	newton metre	0.101972	kilogram-force metre	kgf m
N m	newton metre	0.737562	pound force foot	lbf ft
N m	newton metre	8.85075	pound force inch	lbf in
kgf m	kilogram-force metre	9.80665	newton metre	N m
kgf m	kilogram-force metre	7.23301	pound force foot	lbf ft
kgf m	kilogram-force metre	86.7962	pound force inch	lbf in
lbf in	pound force inch	0.112985	newton metre	N m
lbf in	pound force inch	0.0115212	kilogram-force metre	kgf m
lbf ft	pound force foot	1.35582	newton metre	N m
lbf ft	pound force foot	0.138255	kilogram-force metre	kgf m
Measure	FORCE AND WEIGHT FORCE	multiplying by	to obtain	Measure
N	newton	0.101972	kilogram force	kg
N	newton	0.224809	pound force	lbf
kgf	kilogram force	9.80665	newton	N
kgf	kilogram force	2.20462	pound force	lbf
lbf	pound force	4.44822	newton	N
lbf	pound force	0.453592	kilogram	kgf
ton f (UK)	ton-force UK	9964.02	newton	N
ton f (UK)	ton-force UK	1016.05	kilogram force	kgf
ton f (US)	ton-force US	8896.44	newton	N
ton f (US)	ton-force US	907.185	kilogram force	kgf
tf	ton-force metric	9806.65	newton	N
tf	ton-force metric	1000	kilogram-force	kgf
Measure	MASS/WEIGHT	multiplying by	to obtain	Measure
kg	kilogram	2.20462	pound	lb
kg	kilogram	0,000984 (9.84207x10 ⁻⁴)	ton UK (long ton)	ton UK
kg	kilogram	0.001102	ton US (short ton)	ton US
kg	kilogram	0.001	ton metric	t
lb	pound	0.453592	kilogram	kg
ton UK	ton UK (long ton)	1016.05	kilogram	kg
ton US	ton US (short ton)	907.185	kilogram	kg
t	ton metric	1000	kilogram	kg
Measure	DENSITY	multiplying by	to obtain	Measure
kg/m ³	kilogram per cubic metre	0.62428	pound per cubic foot	lb/ft ³
kg/m ³	kilogram per cubic metre	0,000036 (3.61273x10 ⁻⁵)	pound per cubic inch	lb/in ³
kg/m ³	kilogram per cubic metre	0.001	kilogram per litre	kg/l
lb/ft ³	pound per cubic foot	16,0185	kilogram per cubic metre	kg/m ³
lb/in ³	pound per cubic inch	27679.9	kilogram per cubic metre	kg/m ³
kg/l	kilogram per litre	1000	kilogram per cubic metre	kg/m ³
kg/l	kilogram per litre	62.428	pound per cubic foot	lb/ft ³
kg/l	kilogram per litre	0.036127	pound per cubic inch	lb/in ³
lb/ft ³	pound per cubic foot	0,016018	kilogram per litre	kg/l
lb/in ³	pound per cubic inch	27,6799	kilogram per litre	kg/l
Measure	WEIGHT FOR UNIT OF LENGTH	multiplying by	to obtain	Measure
kg/m	kilogram per metre	0.671972	pound per foot	lb/ft
lb/ft	pound per foot	0.13826	kilogram force per metre	kg/m
Measure	POWER	multiplying by	to obtain	Measure
Hp	horsepower	746	watt	W
CV	horsepower metric	735.499	watt	W
W	watt	0.001340	horsepower	Hp
W	watt	0.001359	horsepower metric	CV



CONVERSION FACTORS

Measure	POWER	multiply by	to obtain	Measure
kW	kilowatt	1000	watt	W
kW	kilowatt	1,34048	horsepower	Hp
kW	kilowatt	1,35962	horsepower metric	CV
Hp	horsepower	0,746	kW kilowatt	kW
CV	horsepower metric	0,735499	kW kilowatt	kW
Measure	PRESSURE	multiply by	to obtain	Measure
Pa (N/m ²)	pascal	0,0000010 (1,01972x10 ⁻³)	kilogram force per square millimetre	kgf/mm ²
Pa (N/m ²)	pascal	0,000010 (1,01972x10 ⁻⁵)	kilogram force per square centimetre	kgf/cm ²
Pa (N/m ²)	pascal	0,00001 (10 ⁻⁵)	bar	bar
Pa (N/m ²)	pascal	0,000009 (9,86923x10 ⁻⁶)	atmosphere	atm
Pa (N/m ²)	pascal	0,020885	pound per square foot	lbf/ft ²
Pa (N/m ²)	pascal	0,000145 (1,45038x10 ⁻⁴)	pound per square inch	lbf/in ² (psi)
Mpa (N/mm ²)	megapascal	0,101972	kilogram force per square millimetre	kgf/mm ²
Mpa (N/mm ²)	megapascal	10,1972	kilogram force per square centimetre	kgf/cm ²
Mpa (N/mm ²)	megapascal	10	bar	bar
Mpa (N/mm ²)	megapascal	9,86923	atmosphere	atm
Mpa (N/mm ²)	megapascal	20885,4	pound per square foot	lbf/ft ²
Mpa (N/mm ²)	megapascal	145,038	pound per square inch	lbf/in ² (psi)
kgf/cm ²	kilogram force per square centimetre	98066,5	pascal	Pa (N/m ²)
kgf/cm ²	kilogram force per square centimetre	0,098066	megapascal	Mpa (N/mm ²)
kgf/cm ²	kilogram force per square centimetre	14,2233	pound force per square foot	lbf/ft ² (psi)
kgf/cm ²	kilogram force per square centimetre	2048,16	pound force per square inch	lbf/in ²
kgf/cm ²	kilogram force per square centimetre	0,980665	bar	bar
kgf/cm ²	kilogram force per square centimetre	0,967841	atmosphere	atm
kgf/mm ²	kilogram force per square millimetre	9806650	Pascal	Pa (N/m ²)
kgf/mm ²	kilogram force per square millimetre	9,80665	megapascal	Mpa (N/mm ²)
kgf/mm ²	kilogram force per square millimetre	1422,33	pound force per square inch	lbf/in ² (psi)
kgf/mm ²	kilogram force per square millimetre	204816	pound force per square foot	lbf/ft ²
kgf/mm ²	kilogram force per square millimetre	98,0665	bar	bar
kgf/mm ²	kilogram force per square millimetre	96,7841	atmosphere	atm
lbf/ft ²	pound force per square foot	47,8803	pascal	Pa (N/m ²)
lbf/ft ²	pound force per square foot	0,000047 (4,78803x10 ⁻⁵)	megapascal	Mpa (N/mm ²)
lbf/ft ²	pound force per square foot	0,000488	kilogram force per square centimetre	kgf/cm ²
lbf/ft ²	pound force per square foot	0,000004 (4,88243x10 ⁻⁶)	kilogram force per square millimetre	kgf/mm ²
lbf/ft ²	pound force per square foot	0,000478 (4,78803x10 ⁻⁴)	bar	bar
lbf/ft ²	pound force per square foot	0,000472 (4,72541x10 ⁻⁴)	atmosphere	atm
lbf/in ² (psi)	pound force per square inch	6894,76	pascal	Pa (N/m ²)
lbf/in ² (psi)	pound force per square inch	0,006894	megapascal	Mpa (N/mm ²)
lbf/in ² (psi)	pound force per square inch	0,070307	kilogram force per square centimetre	kgf/cm ²
lbf/in ² (psi)	pound force per square inch	0,000703 (7,0307x10 ⁻⁴)	kilogram force per square millimetre	kgf/mm ²
lbf/in ² (psi)	pound force per square inch	0,068947	bar	bar
lbf/in ² (psi)	pound force per square inch	0,068046	atmosphere	atm
bar	bar	100000	Pascal	Pa (N/m ²)
bar	bar	0,1	megapascal	Mpa (N/mm ²)
bar	bar	0,986923	atmosphere	atm
atm	atmosphere	101325	Pascal	Pa (N/m ²)
atm	atmosphere	0,101325	megapascal	Mpa (N/mm ²)
atm	atmosphere	1,01325	bar	bar
Measure	FLOW RATE BY MASS	multiply by	to obtain	Measure
kg/sec	kilogram per second	60	kilogram per minute	kg/min
kg/sec	kilogram per second	3600	kilogram per hour	kg/h
kg/sec	kilogram per second	132,277	pound per minute	lb/min
kg/sec	kilogram per second	7936,64	pound per hour	lb/h
kg/sec	kilogram per second	3,6	ton per hour	t/h

CONVERSION FACTORS

Measure	FLOW RATE BY MASS	multiplying by	to obtain	Measure
kg/sec	kilogram per second	3,54314	British ton per hour	ton UK/h
kg/sec	kilogram per second	3,96832	ton USA per hour	ton US/h
kg/min	kilogram per minute	0,016666	kilogram per second	kg/sec
kg/h	kilogram per hour	0,000277 (2,77778x10 ⁻⁴)	kilogram per second	kg/sec
lb/min	pound per minute	0,00755987	kilogram per second	kg/sec
lb/h	pound per hour	0,000125 (1,25998x10 ⁻⁴)	kilogram per second	kg/sec
t/h	ton per hour	0,277778	kilogram per second	kg/sec
ton UK/h	British ton per hour	0,282235	kilogram per second	kg/sec
ton US/h	ton USA per hour	0,251996	kilogram per second	kg/sec
Measure	SPEED	multiplying by	to obtain	Measure
m/sec	metre per second	39,3701	inch per second	in/sec
m/sec	metre per second	2362,2	inch per minute	in/min
m/sec	metre per second	3,28084	foot per second	ft/sec
m/sec	metre per second	196,85	foot per minute	ft/min
m/sec	metre per second	3,6	kilometre per hour	km/h
m/sec	metre per second	2,23694	mile per hour	mi/h
m/min	metre per minute	0,016666	metre per second	m/sec
m/min	metre per minute	0,656168	inch per second	in/sec
m/min	metre per minute	39,3701	inch per minute	in/min
m/min	metre per minute	0,054680	foot per second	ft/sec
m/min	metre per minute	3,28084	foot per minute	ft/min
m/min	metre per minute	0,06	kilometre per hour	km/h
m/min	metre per minute	0,037282	mile per hour	mi/h
in/sec	inch per second	0,0254	metre per second	m/sec
in/min	inch per minute	0,000423 (4,23333x10 ⁻⁴)	metre per second	m/sec
ft/sec	foot per second	0,3048	metre per second	m/sec
ft/min	foot per minute	0,00508	metre per second	m/sec
km/h	kilometre per hour	0,2778	metre per second	m/sec
mi/h	mile per hour	0,44704	metre per second	m/sec
in/sec	inch per second	1,524	metre per minute	m/min
in/min	inch per minute	0,0254	metre per minute	m/min
ft/sec	foot per second	18,288	metre per minute	m/min
ft/min	foot per minute	0,3048	metre per minute	m/min
km/h	kilometre per hour	16,6667	metre per minute	m/min
mi/h	mile per hour	26,82240	metre per minute	m/min
Measure	TEMPERATURE	Applying the following formula	to obtain	Measure
°C	degrees Celsius	$(t_C \times 1,8) + 32$ t_C =temperature °C	degrees Fahrenheit	°F
°F	degrees Fahrenheit	$5/9 \times (t_F - 32)$ t_F =temperature °F	degrees Celsius	°C
K	kelvin	$t_K - 273,15$ t_K = temperature K	degrees Celsius	°C



S
U
S
U
E

NON STANDARD
METRIC PITCH CHAINS



NON STANDARD METRIC PITCH CHAINS

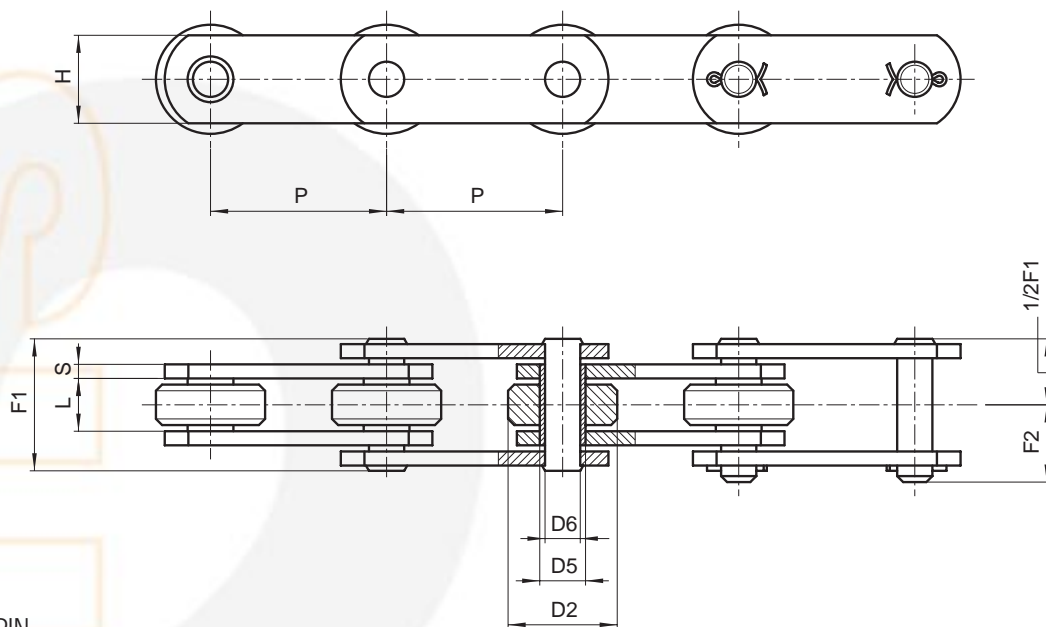

SOLID PIN CHAINS

Chain N.	P mm	L mm	D2 mm	D5 mm	D6 mm	H mm	S mm	F1 mm	F2 mm	Breaking load N	Chain weight kg/m
103	50	11,5	25	8,4	5,7	15	2	24	14,6	16.000	1,4
200	50	11,5	25	8,4	5,7	15	3	28	16,5	18.000	1,7
202	69	11,5	25	8,4	5,7	15	3	28	16,5	18.000	1,5
203	75	11,5	25	8,4	5,7	20	3	28	16,5	18.000	1,7
205	50	11,5	25	8,4	5,7	18	2,5	26	16	18.000	1,7
205SS*	50	11,5	25	8,4	5,7	18	2,5	26	16	18.000	1,7
206	50	11,5	25	11	8	20	3	28	17	30.000	1,9
206SS*	50	11,5	25	11	8	20	3	28	17	22.000	1,9
206R	50	11,5	25	11	8	20	3	28	17	45.000	1,9

(*) STAINLESS steel chain

Additional features:

- rollers of nylon, delrin, etc.
- surface treatments of zinc plating, nickel plating, etc.
- with extended pins
- pre-tensioned and labelled

NON STANDARD METRIC PITCH CHAINS

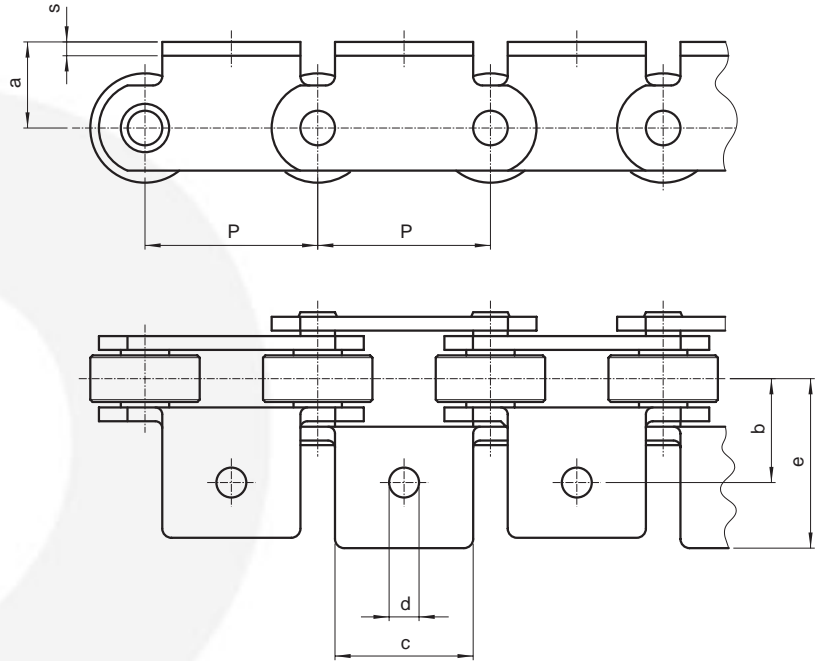

Layout of attachments
on page 1.9/2

ATTACHMENTS

Chain N.	P mm	a mm	b mm	c mm	d mm	e mm	s mm	Weight per attach. kg
103	50	25	21	41	6,5	32	2	0,023
200	50	25	24	41	6,5	34	3	0,035
202	69	27	24	66	6,5	34	3	0,050
203**	75	27	33	46	6,5	46	3	0,055
205	50	24	22	46	6,5	36	2,5	0,035
205B	50	14	32	46	6,5	45	2,5	0,035
205SS	50	24	22	46	6,5	36	2,5	0,035
206	50	24	23	40	6,5	38	3	0,035
206SS	50	24	23	40	6,5	38	3	0,035
206R	50	24	23	40	6,5	38	3	0,035

(**) Chain supplied only with attachments A101/A102



NON STANDARD METRIC PITCH CHAINS

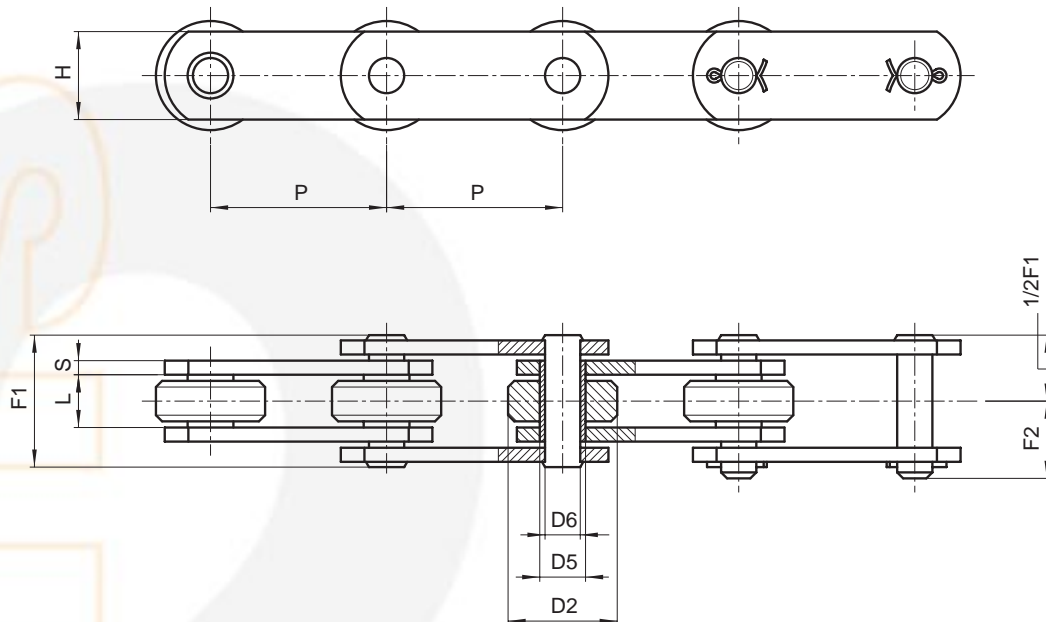

SOLID PIN CHAINS

Chain N.	P mm	L mm	D2 mm	D5 mm	D6 mm	H mm	S mm	F1 mm	F2 mm	Breaking load N	Chain weight kg/m
400**	50	15	31	13,2	10	23	3	33	19,5	35.000	3
400SS*	50	15	31	13,2	10	23	3	33	19,5	30.000	3
401	75	15	31	13,2	10	25	3	33	19,5	35.000	2,8
402	100	15	31	13,2	10	25	3	33	19,5	35.000	2,3
500	50	15	31	13,2	10	25	4	36	21	45.000	3,9
500R	50	15	31	13,2	10	25	4	36	21	75.000	3,9
501	75	15	31	13,2	10	25	4	36	21	45.000	3,2
502	100	15	31	13,2	10	25	4	36	21	45.000	2,7
5021432▲	100	15	31	13,2	10	25	4	36	21	75.000	2,7
503	125	15	31	13,2	10	25	4	36	21	45.000	2,5
504	150	15	31	13,2	10	25	4	36	21	45.000	2,4
701	75	22	40	17	12	35	4	43	25	75.000	5,9
703	100	22	40	17	12	35	4	43	25	75.000	4,9
W1743▲	100	24	40	17	12	35	4	45	26	75.000	6,3
704	125	22	40	17	12	35	4	43	25	75.000	4,4
705	150	22	40	17	12	35	4	43	25	75.000	4

▲ chain only with attachments

(*) STAINLESS steel chain
 (***) Chain with shaped plates

- Additional features:
- rollers of nylon, delrin, etc.
 - surface treatments of zinc plating, nickel plating, etc.
 - bush chain (without roller)
 - with extended pins
 - pre-tensioned and labelled

NON STANDARD METRIC PITCH CHAINS

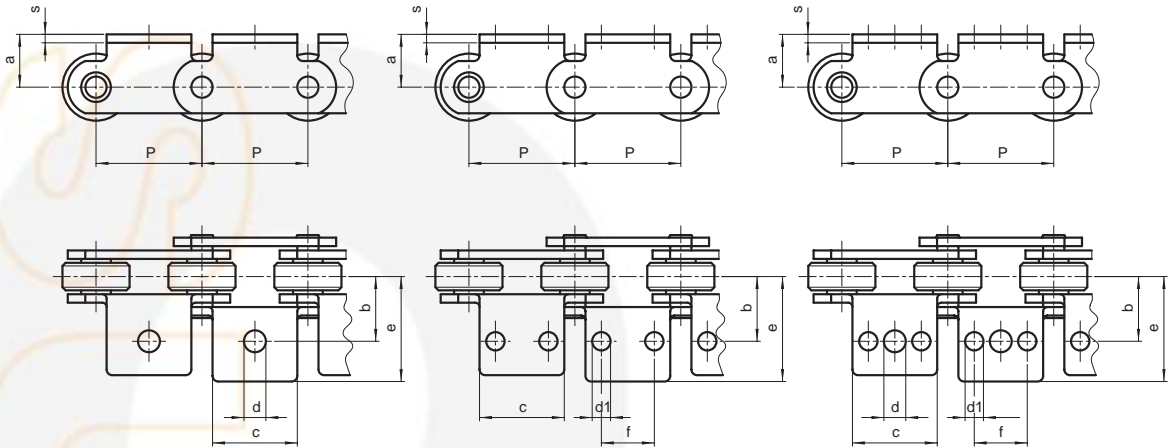

Layout of attachments
on page 1.9/2

ATTACHMENTS

Chain N.	Attachments assembly	P mm	a mm	b mm	c mm	d mm	d1 mm	e mm	f mm	s mm	Weight per attach. kg
400	only on outer links	50	35	31	60	10	8,5	48,5	25	3	0,080
400	all	50	28	31	30	10	/	46	/	3	0,035
400B	all	50	16,5	42	30	10	/	57	/	3	0,035
400B	only on outer links	50	16,5	31	60	10	8,5	48,5	25	3	0,050
400SS	all	50	28	31	30	10	/	46	/	3	0,035
400SS	only on outer links	50	35	31	60	10	8,5	48,5	25	3	0,080
401 ● ♣	all	75	30	28	60	10	9	41,5	30	3	0,060
402 □	all	100	35	31	70	10	9	46,5	35	3	0,085
500 ● ♣	all	50	35	32	45	10	8,5	48,5	25	4	0,070
500B ● ♣	all	50	22	45	45	10	8,5	61,5	25	4	0,070
500BR ● ♣	only on outer links	50	17,5	34	60	10	9	50	30	4	0,070
501 □	all	75	30	29	60	10	9	44,5	30	4	0,080
502 □	all	100	35	32	70	10	9	48,5	35	4	0,100
5021432 □	all	100	-1,5	30 ■	60	9	6,5	46	40	4	0,025
503 □ *	all	125	35	32	70	10	9	56	35	4	0,160
504 ♣ *	all	150	35	32	100	10	9	56	35	4	0,250
701 ♣	all	75	26	38	50	10	9	66,5	25	4	0,100
703 □	all	100	40	38	70	10	9	58	35	4	0,140
703B □	all	100	26	38	70	10	9	66,5	35	4	0,120
W1743 ●	all	100	26	38	70	16,5	/	73	35	4	0,140
704 □	all	125	26	40	100	10	9	62,5	70	4	0,150
705 ♣	all	150	26	40	100	10	9	56,5	50	4	0,180

- attachments with 1 hole
- ♣ attachments with 2 holes
- attachments with 3 holes
- * welded attachments
- central hole: b=32,5



NON STANDARD METRIC PITCH CHAINS

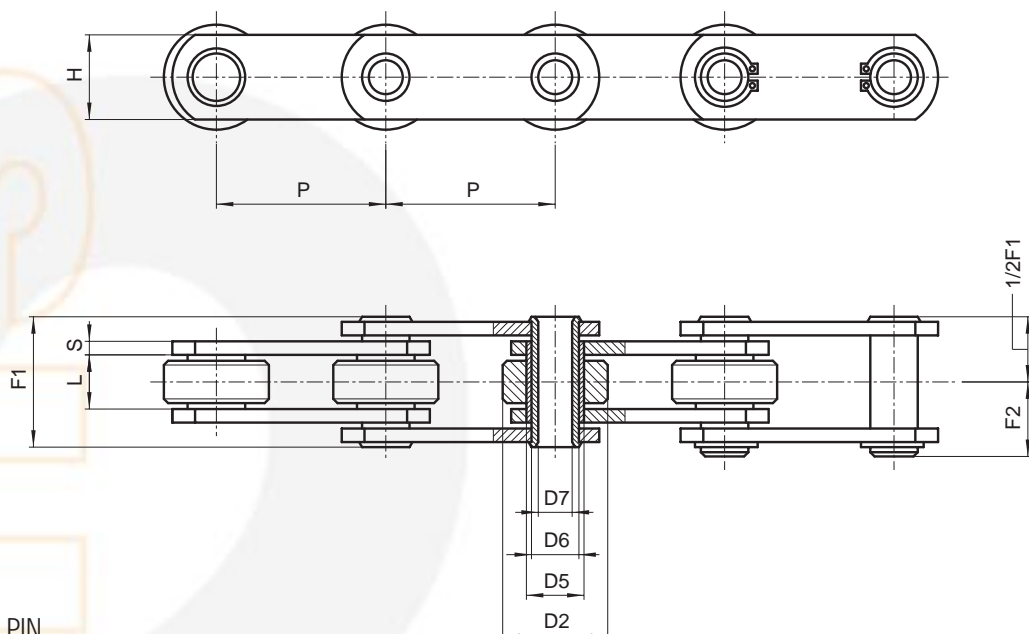

HOLLOW PIN CHAINS

Chain N.	P mm	L mm	D2 mm	D5 mm	D6 mm	D7 mm	H mm	S mm	F1 mm	F2 mm	Breaking load N	Chain weight kg/m
250	50	11,5	25	11	9	6,2	20	2,5	25	14	25.000	1,8
250R	50	11,5	25	11	9	6,2	20	2,5	25	14	38.000	1,8
250SS*	50	11,5	25	11	9	6,2	20	2,5	25	14	25.000	1,8
400C**	50	15	31	17	14	10,2	25	3	31	17	35.000	3
W3635	50	15	31	17	14	10,2	25	3	31	17	35.000	3
500C	50	15	31	17	14	10,2	25	4	35	18,5	40.000	3,6
500CRP***	50	15	31	17	14	10,2	25	4	35	18,5	65.000	3,6
500CSS*	50	15	31	17	14	10,2	25	4	35	20	40.000	3,6
501C	75	15	31	17	14	10,2	25	4	35	18,5	40.000	3,1
501CSS*	75	15	31	17	14	10,2	25	4	35	20	40.000	3,1
502C	100	15	31	17	14	10,2	25	4	35	18,5	40.000	2,6
502CSS*	100	15	31	17	14	10,2	25	4	35	20	40.000	2,6
503C	125	15	31	17	14	10,2	25	4	35	18,5	40.000	2,4
503CSS*	125	15	31	17	14	10,2	25	4	35	20	40.000	2,4
504C	150	15	31	17	14	10,2	25	4	35	18,5	40.000	2,3
701C	75	22	40	23	18	12,2	35	4	45	23,5	60.000	4,6
703C	100	22	40	23	18	12,2	35	4	45	23,5	60.000	4,4
703CR	100	22	40	23	18	12,2	35	4	45	23,5	75.000	4,4
704C	125	22	40	23	18	12,2	35	4	45	23,5	60.000	4,2
704CR	125	22	40	23	18	12,2	35	4	45	23,5	75.000	4,2
705C	150	22	40	23	18	12,2	35	4	45	23,5	60.000	4
705CR	150	22	40	23	18	12,2	35	4	45	23,5	75.000	4

(*) STAINLESS steel chain
 (**) Chain with shaped plates
 (***) Pre-tensioned and labelled

Additional features:
 - rollers of nylon, delrin, etc.
 - surface treatments of zinc plating, nickel plating, etc.
 - bush chain (without roller)
 - pre-tensioned and labelled

NON STANDARD METRIC PITCH CHAINS

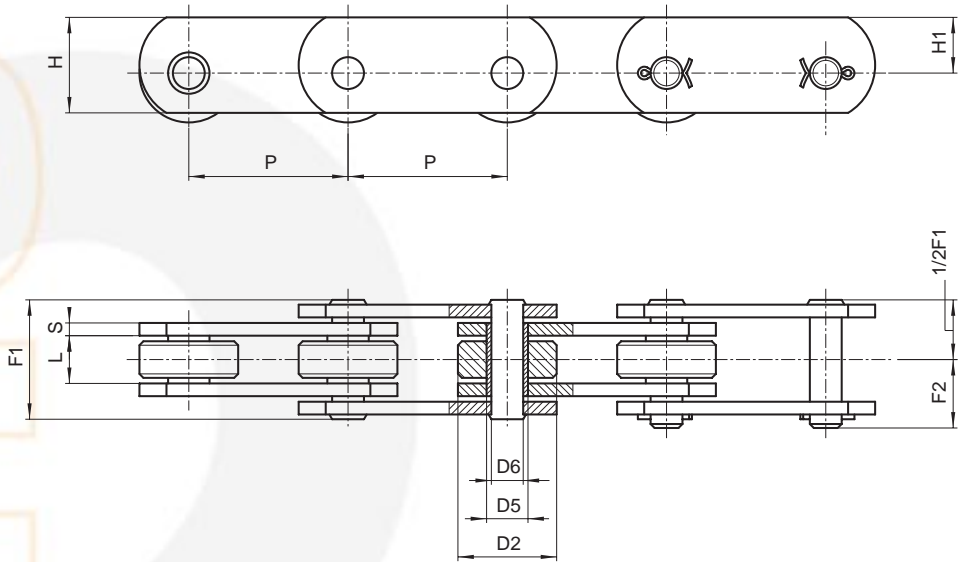

DEEP LINK CHAINS

Chain N.	P mm	L mm	D2 mm	D5 mm	D6 mm	H mm	H1 mm	S mm	F1 mm	F2 mm	Breaking load N	Chain weight kg/m
350Z**	50	11,5	18	8,4	5,7	17,5	10	2,5	25,5	15,5	18.000	1,25
351	50	11,5	25	8,4	5,7	25	16,5	2	24	15	16.000	2
352	50	15	31	13,2	10	30	17,5	4	36	21	45.000	4,5
352SS*	50	15	31	13,2	10	30	17,5	4	36	21	45.000	4,5
353	75	15	31	13,2	10	30	17,5	4	36	21	45.000	3,8
353SS*	75	15	31	13,2	10	30	17,5	4	36	21	45.000	3,8
354	100	15	31	13,2	10	30	17,5	4	36	21	45.000	3,5
354SS*	100	15	31	13,2	10	30	17,5	4	36	21	45.000	3,5

(*) STAINLESS steel chain

(**) Zinc plated chain

Additional features:

- rollers of nylon, delrin, etc.
- surface treatments of zinc plating, nickel plating, etc.
- pre-tensioned and labelled



NON STANDARD CHAINS

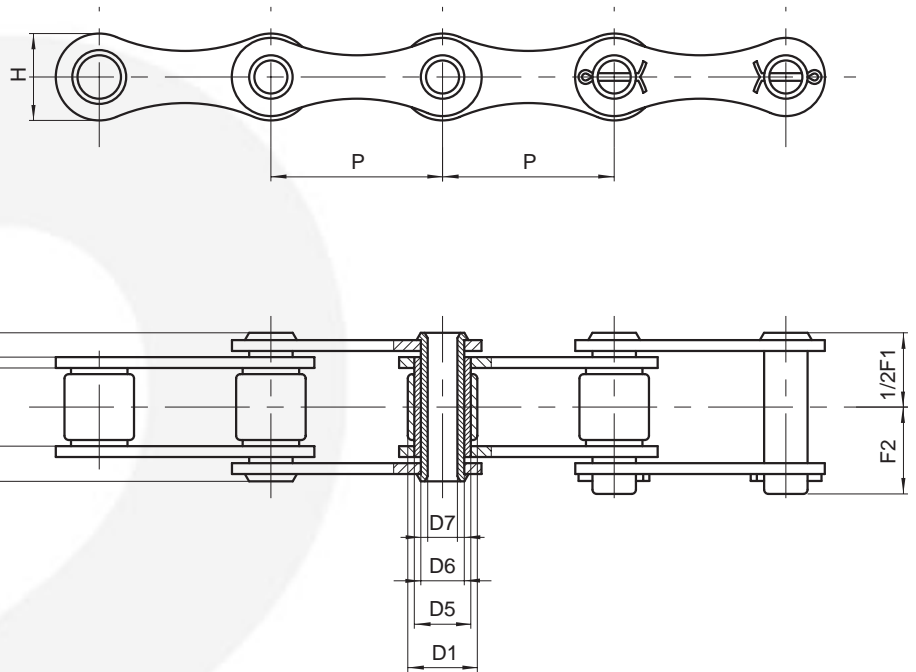

HOLLOW PIN CHAINS

Chain N.	P mm	L mm	D1 mm	D5 mm	D6 mm	D7 mm	H mm	S mm	F1 mm	F2 mm	Breaking load N	Chain weight kg/m
260	41,75	20,5	17	13,8	11	8,3	22	3	36	22,7	27.000	1,5
260SS*	41,75	20,5	17	13,8	11	8,3	22	3	36	22,7	13.500	1,5
260RZ**	41,75	20,5	17	13,8	11	8,3	25	3	36	22,7	35.000	1,9
260RBZ**	41,75	20,5	17	13,8	11	8,3	25	3	36	22,7	50.000	1,9

(*) STAINLESS steel chain

(**) Zinc plated chain

Additional features:

- rollers of nylon, delrin, etc.
- surface treatments of zinc plating, nickel plating, etc.
- pre-tensioned and labelled



NON STANDARD CHAINS

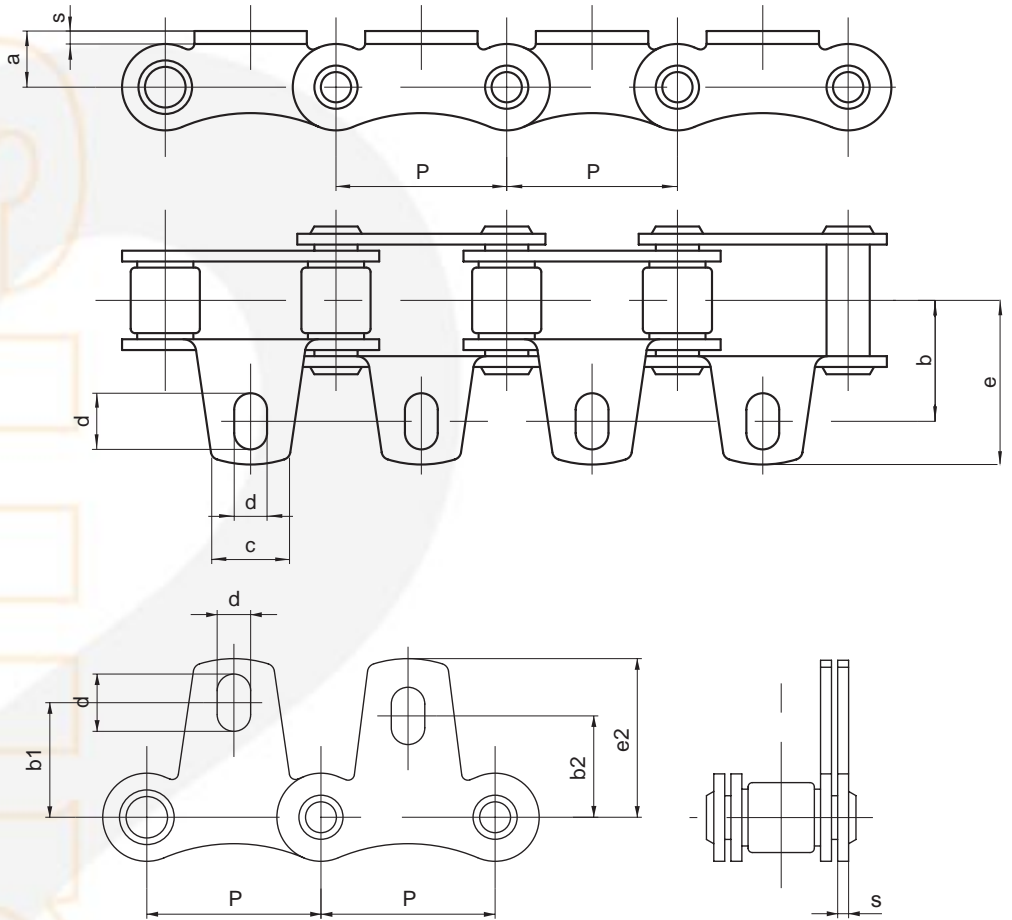

ATTACHMENTS

Chain N.	P mm	a mm	b mm	b1 mm	b2 mm	c mm	d mm	e mm	e1 mm	s mm	Weight per attach. kg
260	41,75	13,5	30	29	25	19	14-8,3	43,5	39,5	3	0,020
260SS	41,75	13,5	30	29	25	19	14-8,3	43,5	39,5	3	0,020



NON STANDARD CHAINS

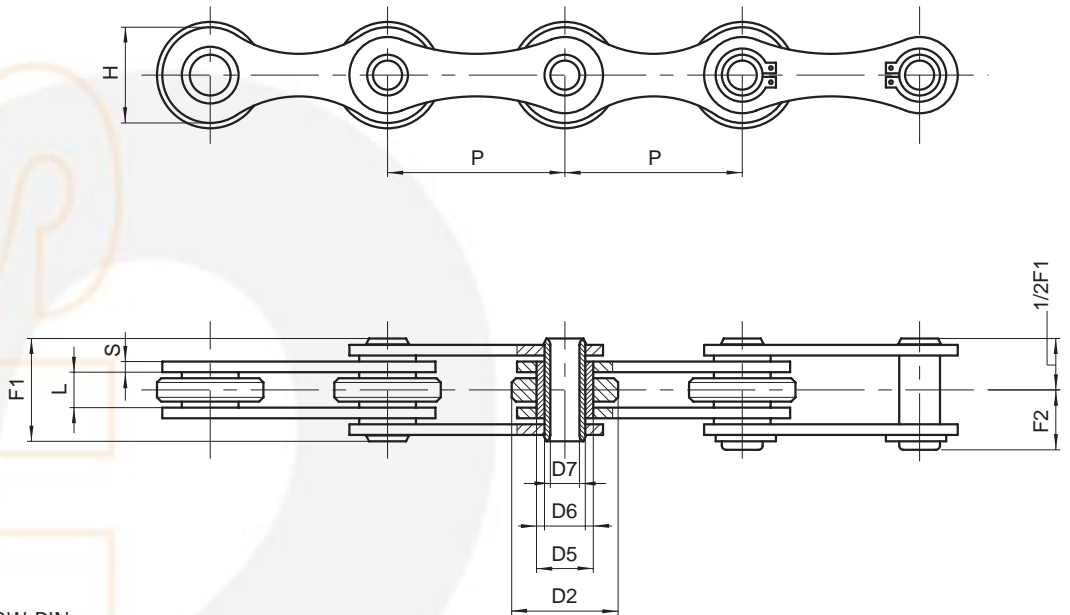

HOLLOW PIN CHAINS

Chain N.	P mm	L mm	D2 mm	D5 mm	D6 mm	D7 mm	H mm	S mm	F1 mm	F2 mm	Breaking load N	Chain weight kg/m
261	50	10	30	16	11,5	8,2	25,5	3	26,5	14,5	60.000	2,2
262	50,8	10	30	16	11,5	8,2	25,5	3	26,5	14,5	60.000	2,1
262SS*	50,8	10	30	16	11,5	8,2	25,5	3	26,5	14,5	32.000	2,1
W3865AR	60	10	30	16	11,5	8,2	26	3	26,5	14,5	60.000	1,5
W3604R	63	10	30	16	11,5	8,2	26	3	26,5	14,5	60.000	2,3
263	100	10	30	16	11,5	8,2	25,5	3	26,5	14,5	60.000	1,5

(*) STAINLESS steel chain

Additional features:

- rollers of nylon, delrin, etc.
- surface treatments of zinc plating, nickel plating, etc.
- pre-tensioned and labelled





S
U
N
S
N
E

BRITISH STANDARD CHAINS,
BS 4116 PART 4 (Z series)



BRITISH STANDARD CHAINS, BS 4116 PART 4

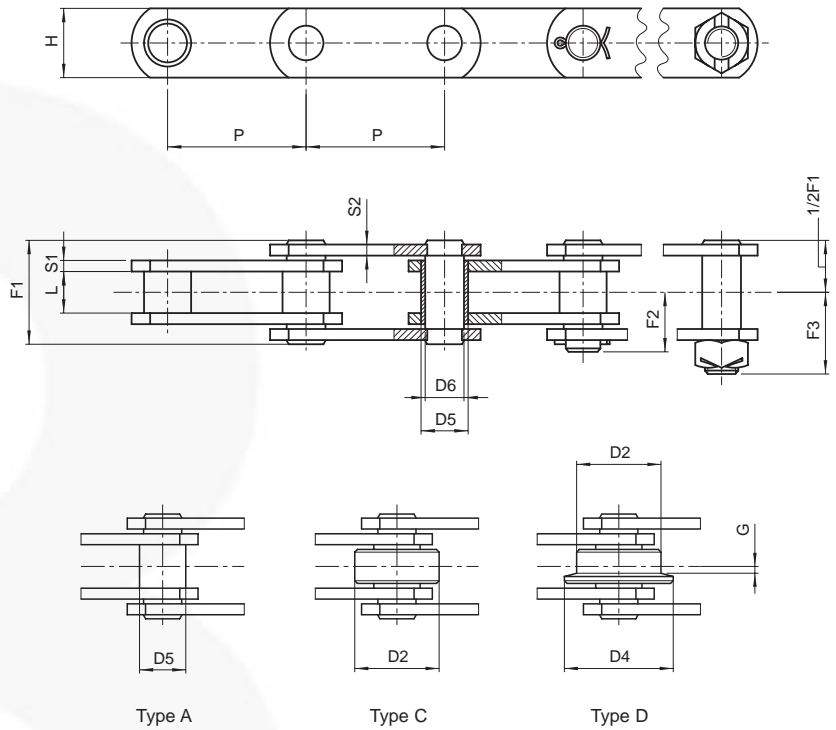

SOLID PIN CHAINS

Chain N.	P inches	P mm	L mm	D2 mm	D4 mm	G mm	D5 mm	D6 mm	H mm	S1 mm	S2 mm	F1 mm	F2 mm	F3 mm	Breaking load	
															N	N*
7500 lbf Z40	2	50,8	15	31,75	40	2,5	17	14	25	4	4	37	22	28,5	40.000	50.000
"	2,5	63,5	"	"	"	"	"	"	"	"	"	"	"	"	"	"
"	3	76,2	"	"	"	"	"	"	"	"	"	"	"	"	"	"
"	3,5	88,9	"	"	"	"	"	"	"	"	"	"	"	"	"	"
"	4	101,6	"	"	"	"	"	"	"	"	"	"	"	"	"	"
"	5	127	"	"	"	"	"	"	"	"	"	"	"	"	"	"
"	6	152,4	"	"	"	"	"	"	"	"	"	"	"	"	"	"
15000 lbf Z100	3	76,2	19	47,5	60	3,5	23**	19	40	5	4	45	28	37	100.000	130.000
"	3,5	88,9	"	"	"	"	"	"	"	"	"	"	"	"	"	"
"	4	101,6	"	"	"	"	"	"	"	"	"	"	"	"	"	"
"	5	127	"	"	"	"	"	"	"	"	"	"	"	"	"	"
"	6	152,4	"	"	"	"	"	"	"	"	"	"	"	"	"	"
"	7	177,8	"	"	"	"	"	"	"	"	"	"	"	"	"	"
"	8	203,2	"	"	"	"	"	"	"	"	"	"	"	"	"	"

(*) Breaking load with heat treated plates

(**) Ø 24 mm. for chain type "A"

- Additional features:
- metric pitch
 - rollers of nylon, delrin, etc.
 - with extended pins
 - in STAINLESS steel
 - surface treatments of zinc plating, nickel plating, etc.
 - pre-tensioned and labelled



BRITISH STANDARD CHAINS, BS 4116 PART 4

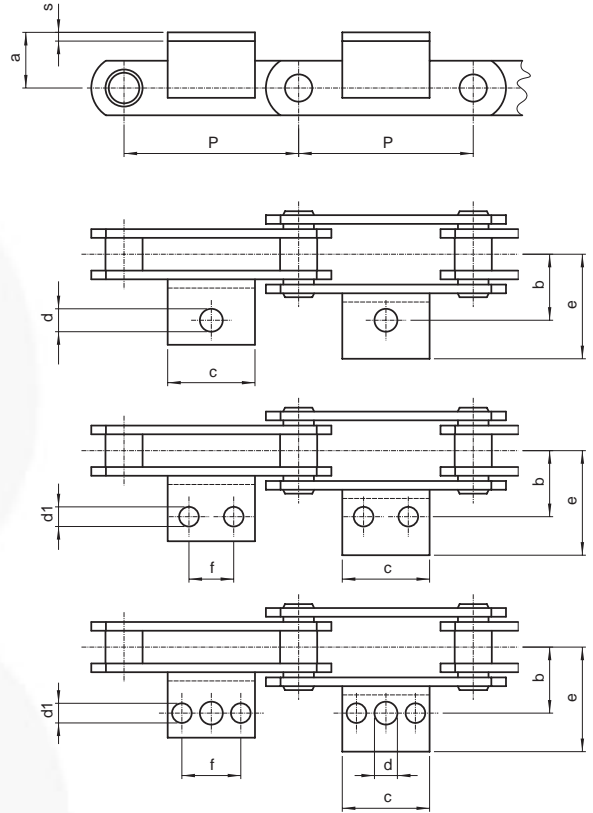

Layout of attachments on page 1.9/2

ATTACHMENTS

Chain N.	Symbol	P mm	a mm	b mm	c mm	d mm	d1 mm	e mm	f mm	Angle mm	Chain weight			Weight per attach. kg
											type A	type C	type D	
Z40	●*	50,8	19	38,1	45	10,7	/	64,5	/	/	3	4,2	4,4	0,100
"	●♣	63,5	"	"	43	"	9,3	56	22,2	40x25x4	2,8	3,8	3,9	0,100
"	□*	76,2	"	"	"	"	"	68	"	/	2,5	3,3	3,4	0,100
"	□	88,9	"	"	50	"	"	56	31,8	40x25x4	2,4	3,1	3,2	0,100
"	□*	101,6	"	"	64	"	"	55	"	/	2,3	2,9	3	0,100
"	□	127	"	"	84	"	"	56	57,2	40x25x4	2,1	2,6	2,7	0,200
"	□	152,4	"	"	"	"	"	"	"	"	1,9	2,4	2,5	0,200
Z100	●	76,2	32	44,5	30	14	/	65	/	45x5	4,9	7,7	8,2	0,100
"	●	88,9	"	"	"	"	/	"	/	"	4,7	7,1	7,5	0,100
"	□*	101,6	"	"	64	"	10,5	"	31,8	/	4,6	6,5	7	0,100
"	●♣	127	"	"	84	"	"	"	57,2	45x5	4,3	5,6	6,2	0,300
"	□*	152,4	"	"	114,5	"	"	"	"	/	4,1	5,2	5,7	0,300
"	●♣	177,8	"	"	110	"	"	"	80	45x5	3,9	4,8	5,2	0,400
"	●♣	203,2	"	"	"	"	"	"	"	"	3,8	4,6	5	0,400

- attachments with 1 hole
- ♣ attachments with 2 holes
- attachments with 3 holes
- * integral attachments



BRITISH STANDARD CHAINS, BS 4116 PART 4

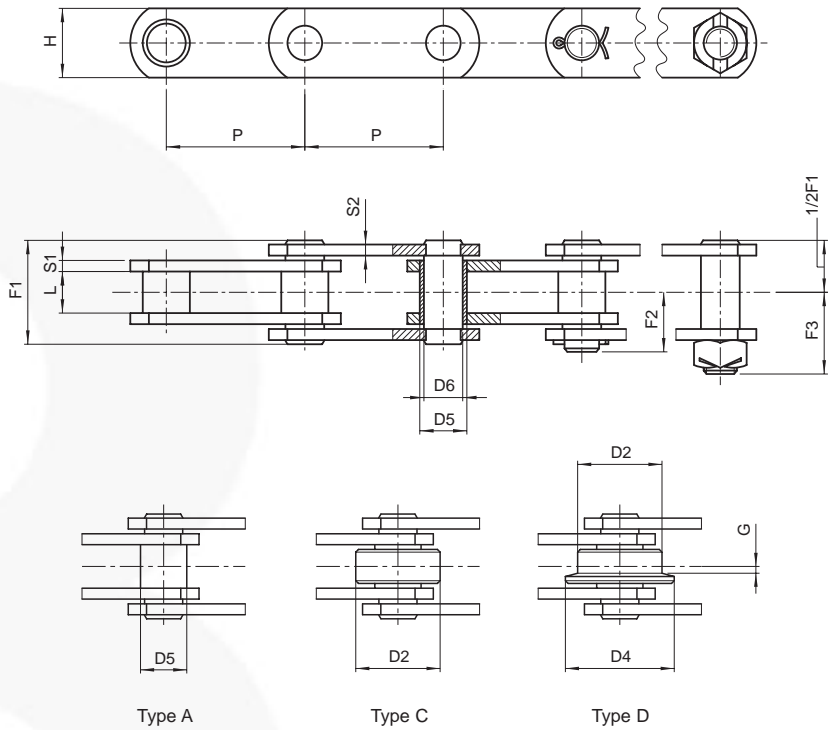

SOLID PIN CHAINS

Chain N.	P inches	P mm	L mm	D2 mm	D4 mm	G mm	D5 mm	D6 mm	H mm	S1 mm	S2 mm	F1 mm	F2 mm	F3 mm	Breaking load N	Breaking load N*
30000 lbf																
Z160	4	101,6	26	66,7	82	3,5	33	26,9	50	7	5	58	34,5	51,0	156.000	200.000
"	5	127	"	"	"	"	"	"	"	"	"	"	"	"	"	"
"	6	152,4	"	"	"	"	"	"	"	"	"	"	"	"	"	"
"	7	177,8	"	"	"	"	"	"	"	"	"	"	"	"	"	"
"	8	203,2	"	"	"	"	"	"	"	"	"	"	"	"	"	"
"	9	228,6	"	"	"	"	"	"	"	"	"	"	"	"	"	"
"	10	254	"	"	"	"	"	"	"	"	"	"	"	"	"	"
60000 lbf																
Z300	6	152,4	38	88,9	114	8,5	38	32	60	10	8	84	52	71,0	300.000	380.000
"	7	177,8	"	"	"	"	"	"	"	"	"	"	"	"	"	"
"	8	203,2	"	"	"	"	"	"	"	"	"	"	"	"	"	"
"	10	254	"	"	"	"	"	"	"	"	"	"	"	"	"	"
"	12	304,8	"	"	"	"	"	"	"	"	"	"	"	"	"	"

(*) Breaking load with heat treated plates

- Additional features:
- metric pitch
 - rollers of nylon, delrin, etc.
 - with extended pins
 - in STAINLESS steel
 - surface treatments of zinc plating, nickel plating, etc.
 - pre-tensioned and labelled



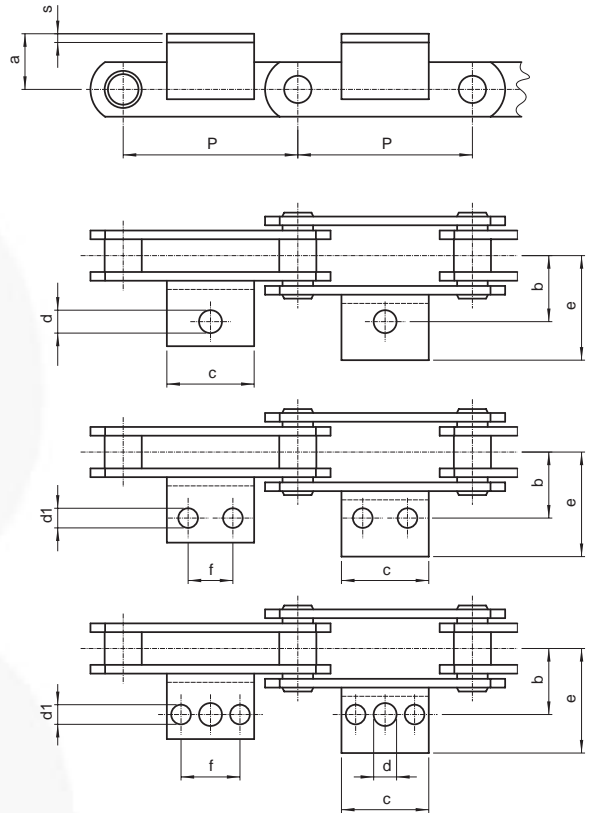

Layout of attachments on page 1.9/2

ATTACHMENTS

Chain N.		P mm	a mm	b mm	c mm	d mm	d1 mm	e mm	f mm	Angle mm	Chain weight			Weight per attach. kg
											type A	type C	type D	
Z160	●	101,6	38	54	35	15,5	/	77	/	/	8,8	13,7	14,9	0,200
"	●♣	127	"	"	56	"	12,3	"	31,7	50x6	8	11,8	12,8	0,300
"	●♣	152,4	"	"	84	"	"	"	57,2	"	7,5	10,8	11,5	0,400
"	●♣	177,8	"	"	"	"	"	"	"	"	7	9,8	10,5	0,400
"	●♣	203,2	"	"	130	"	"	"	100	"	6,7	9,2	9,7	0,600
"	●♣	228,6	"	"	150	"	"	"	"	"	6	8,9	9,1	0,700
"	●♣	254	"	"	170	"	"	"	135	"	5,6	7,6	8,0	0,700
Z300	●	152,4	51	73	70	17	14	100	38,1	60x8	14,7	24,3	26,0	0,500
"	●	177,8	"	"	"	"	"	"	"	"	13,7	22,0	23,5	0,500
"	●♣	203,2	"	"	100	"	"	"	76,2	"	13,1	20,5	21,6	0,700
"	●♣	254	"	"	152,4	"	"	"	90	"	12,2	18,0	19,0	0,900
"	●♣	304,8	"	"	225	"	"	"	190	"	11,6	16,5	17,5	1,600

- attachments with 1 hole
- ♣ attachments with 2 holes
- attachments with 3 holes



BRITISH STANDARD CHAINS, BS 4116 PART 4

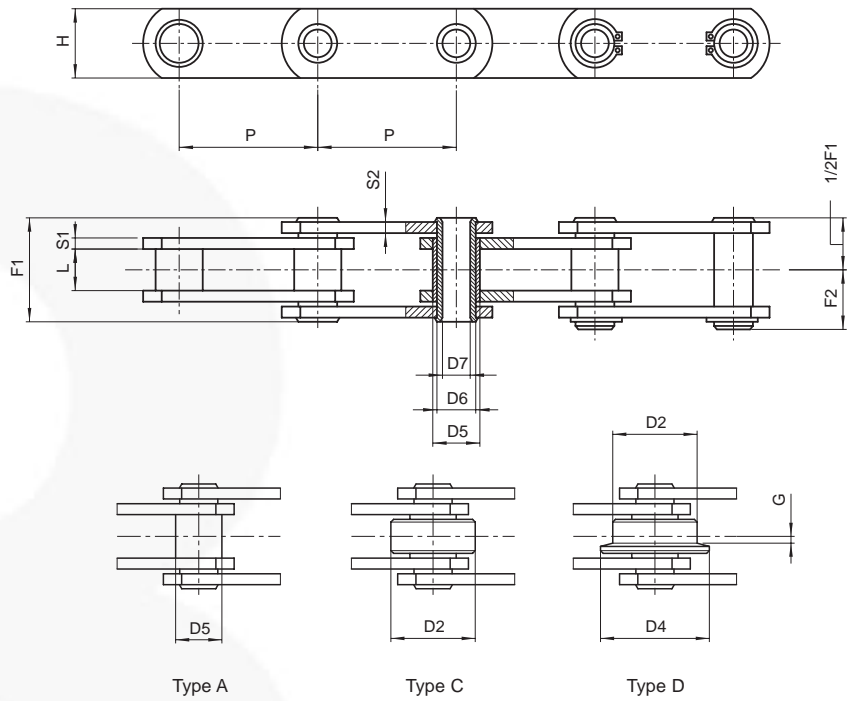

HOLLOW PIN CHAINS

Chain N.	P inches	P mm	L mm	D2 mm	D4 mm	G mm	D5 mm	D6 mm	D7 mm	H mm	S1 mm	S2 mm	F1 mm	F2 mm	Breaking load		Chain weight kg/m**
															N	N*	
4500 lbf ZC21	1,5	38,1	12,7	25,4	/	/	11	9	6,5	18	2,5	2,5	26	14,5	21.000	/	2,1
"	2	50,8	"	"	"	"	"	"	"	"	"	"	"	"	"	"	1,7
"	2,5	63,5	"	"	"	"	"	"	"	"	"	"	"	"	"	"	1,6
"	3	76,2	"	"	"	"	"	"	"	"	"	"	"	"	"	"	1,4
6000 lbf ZC40	2	50,8	15	31,75	40	2,5	17	14	10,2	25	4	4	36,4	19,5	40.000	50.000	3,6
"	2,5	63,5	"	"	"	"	"	"	"	"	"	"	"	"	"	"	3,3
"	3	76,2	"	"	"	"	"	"	"	"	"	"	"	"	"	"	3
"	3,5	88,9	"	"	"	"	"	"	"	"	"	"	"	"	"	"	2,8
"	4	101,6	"	"	"	"	"	"	"	"	"	"	"	"	"	"	2,6
"	5	127	"	"	"	"	"	"	"	"	"	"	"	"	"	"	2,4
"	6	152,4	"	"	"	"	"	"	"	"	"	"	"	"	"	"	2,3
12000 lbf ZC60	3	76,2	19	47,5	60	3,5	23▲	19	13,2	40	5	4	45	23,5	60.000	120.000	6,9
"	3,5	88,9	"	"	"	"	"	"	"	"	"	"	"	"	"	"	6,4
"	4	101,6	"	"	"	"	"	"	"	"	"	"	"	"	"	"	5,9
"	5	127	"	"	"	"	"	"	"	"	"	"	"	"	"	"	5,3
"	6	152,4	"	"	"	"	"	"	"	"	"	"	"	"	"	"	4,9
"	7	177,8	"	"	"	"	"	"	"	"	"	"	"	"	"	"	4,6
"	8	203,2	"	"	"	"	"	"	"	"	"	"	"	"	"	"	4,4

▲ \varnothing 24 mm for chain type "A"

(*) Breaking load with heat treated plates

(**) Weight for chain with roller "Type C"

Additional features:

- metric pitch
- rollers of nylon, delrin, etc.
- in STAINLESS steel
- surface treatments of zinc plating, nickel plating, etc.
- pre-tensioned and labelled



BRITISH STANDARD CHAINS, BS 4116 PART 4

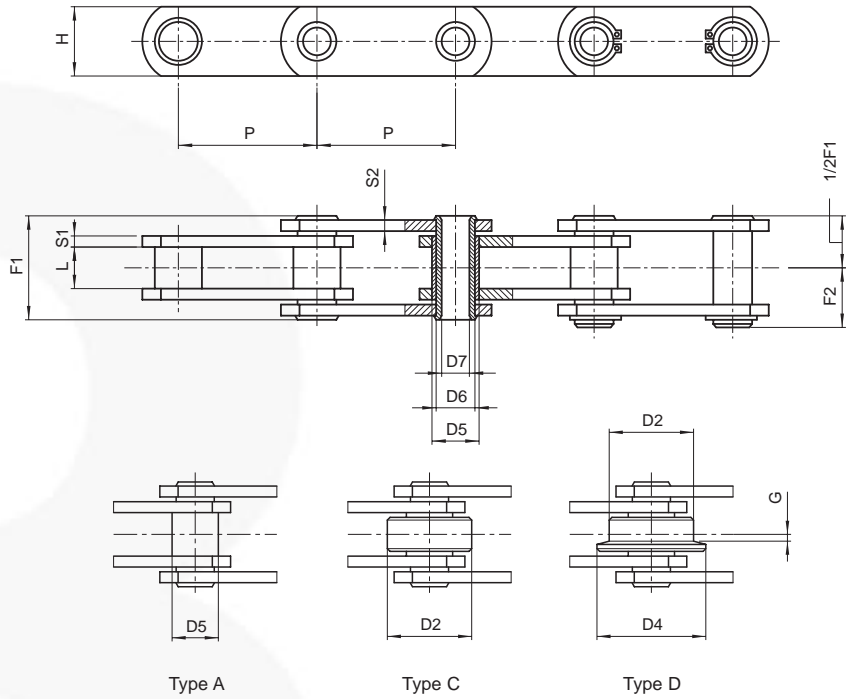

HOLLOW PIN CHAINS

Chain N.	P inches	P mm	L mm	D2 mm	D4 mm	G mm	D5 mm	D6 mm	D7 mm	H mm	S1 mm	S2 mm	F1 mm	F2 mm	Breaking load		Chain weight kg/m**
															N	N*	
24000 lbf ZC150	4	101,6	26	66,7	82	4	33	26,9	20,2	50	7	5	58	31,5	150.000	190.000	12
"	5	127	"	"	"	"	"	"	"	"	"	"	"	"	"	"	10,8
"	6	152,4	"	"	"	"	"	"	"	"	"	"	"	"	"	"	9,8
"	7	177,8	"	"	"	"	"	"	"	"	"	"	"	"	"	"	9
"	8	203,2	"	"	"	"	"	"	"	"	"	"	"	"	"	"	8,5
"	9	228,6	"	"	"	"	"	"	"	"	"	"	"	"	"	"	8,2
"	10	254	"	"	"	"	"	"	"	"	"	"	"	"	"	"	7,7
36000 lbf ZC300	6	152,4	38	88,9	114	8,5	38	32	22,5	60	10	8	83	43,5	300.000	380.000	22,1
"	7	177,8	"	"	"	"	"	"	"	"	"	"	"	"	"	"	20
"	8	203,2	"	"	"	"	"	"	"	"	"	"	"	"	"	"	18,6
"	10	254	"	"	"	"	"	"	"	"	"	"	"	"	"	"	16,4
"	12	304,8	"	"	"	"	"	"	"	"	"	"	"	"	"	"	15,3

(*) Breaking load with heat treated plates

(**) Weight for chain with roller "Type C"

Additional features:

- metric pitch
- rollers of nylon, delrin, etc.
- in STAINLESS steel
- surface treatments of zinc plating, nickel plating, etc.
- pre-tensioned and labelled



BRITISH STANDARD CHAINS, BS 4116 PART 4

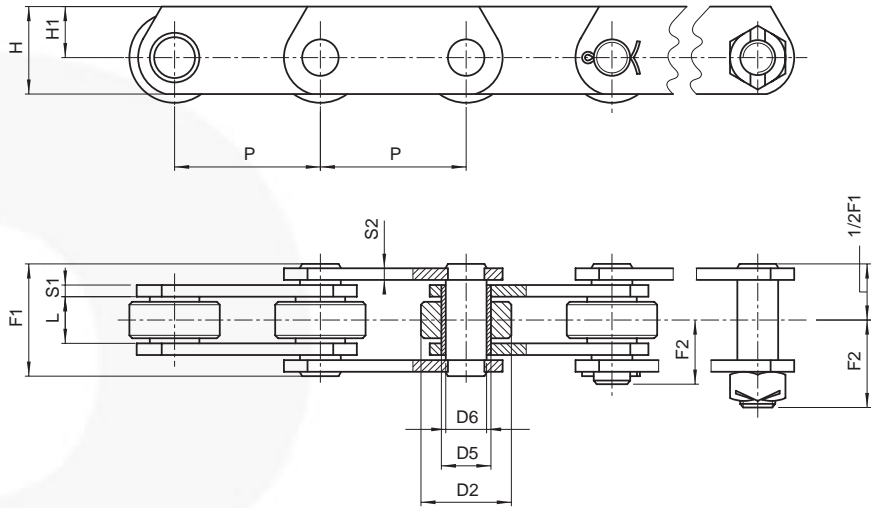

DEEP LINK CHAINS

Chain N.	P inches	P mm	L mm	D2 mm	D5 mm	D6 mm	H mm	H1 mm	S1 mm	S2 mm	F1 mm	F2 mm	F3 mm	Breaking load		Chain weight kg/m
														N	N*	
7500 lbf																
ZE40	2	50,8	15	31,75	17	14	40	27	4	4	37	22	28,5	40.000	60.000	5,6
"	2,5	63,5	"	"	"	"	"	"	"	"	"	"	"	"	"	5,1
"	3	76,2	"	"	"	"	"	"	"	"	"	"	"	"	"	4,4
"	3,5	88,9	"	"	"	"	"	"	"	"	"	"	"	"	"	4,1
"	4	101,6	"	"	"	"	"	"	"	"	"	"	"	"	"	3,9
"	5	127	"	"	"	"	"	"	"	"	"	"	"	"	"	3,6
"	6	152,4	"	"	"	"	"	"	"	"	"	"	"	"	"	3,3
15000 lbf																
ZE100	3	76,2	19	47,5	23	19	50	30	5	4	45	28	37	100.000	160.000	9,2
"	3,5	88,9	"	"	"	"	"	"	"	"	"	"	"	"	"	8,5
"	4	101,6	"	"	"	"	"	"	"	"	"	"	"	"	"	7,8
"	5	127	"	"	"	"	"	"	"	"	"	"	"	"	"	6,9
"	6	152,4	"	"	"	"	"	"	"	"	"	"	"	"	"	6,4
"	7	177,8	"	"	"	"	"	"	"	"	"	"	"	"	"	6
"	8	203,2	"	"	"	"	"	"	"	"	"	"	"	"	"	5,7

(*) Breaking load with heat treated plates

Additional features:

- metric pitch
- rollers of nylon, delrin, etc.
- in STAINLESS steel
- surface treatments of zinc plating, nickel plating, etc.
- pre-tensioned and labelled



BRITISH STANDARD CHAINS, BS 4116 PART 4

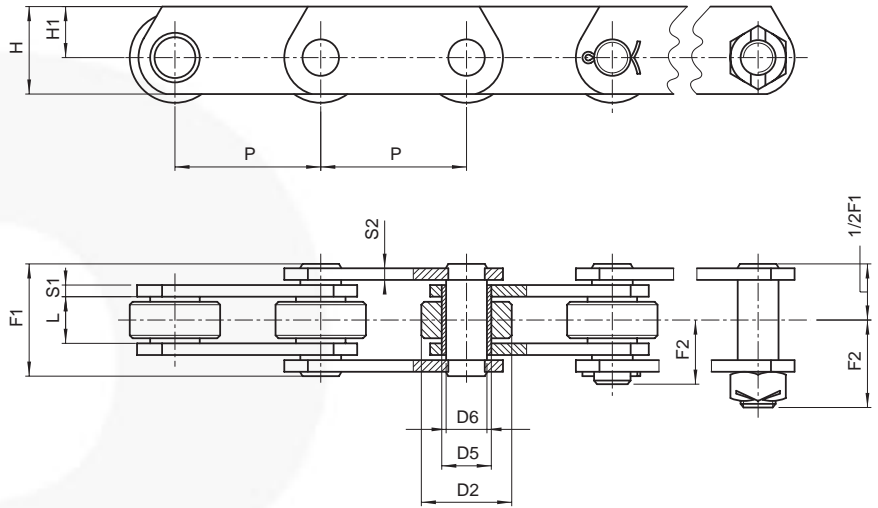

DEEP LINK CHAINS

Chain N.	P inches	P mm	L mm	D2 mm	D5 mm	D6 mm	H mm	H1 mm	S1 mm	S2 mm	F1 mm	F2 mm	F3 mm	Breaking load		Chain weight kg/m
														N	N*	
30000 lbf ZE160	4	101,6	26	66,7	33	26,9	70	45	7	5	58	34,5	51	160.000	200.000	17,6
"	5	127	"	"	"	"	"	"	"	"	"	"	"	"	"	15,4
"	6	152,4	"	"	"	"	"	"	"	"	"	"	"	"	"	13,9
"	7	177,8	"	"	"	"	"	"	"	"	"	"	"	"	"	12,9
"	8	203,2	"	"	"	"	"	"	"	"	"	"	"	"	"	12,1
"	9	228,6	"	"	"	"	"	"	"	"	"	"	"	"	"	11,5
"	10	254	"	"	"	"	"	"	"	"	"	"	"	"	"	11
60000 lbf ZE300	6	152,4	38	88,9	38	32	90	60	10	8	84	52	71	300.000	380.000	32,2
"	7	177,8	"	"	"	"	"	"	"	"	"	"	"	"	"	29,4
"	8	203,2	"	"	"	"	"	"	"	"	"	"	"	"	"	27,3
"	10	254	"	"	"	"	"	"	"	"	"	"	"	"	"	24,4
"	12	304,8	"	"	"	"	"	"	"	"	"	"	"	"	"	22,5

(*) Breaking load with heat treated plates

Additional features:

- metric pitch
- rollers of nylon, delrin, etc.
- in STAINLESS steel
- surface treatments of zinc plating, nickel plating, etc.
- pre-tensioned and labelled





ISO
1977
DIN
8167
M
series

METRIC CHAINS, ISO 1977
DIN 8167 (M series)



METRIC CHAINS, ISO 1977 – DIN 8167

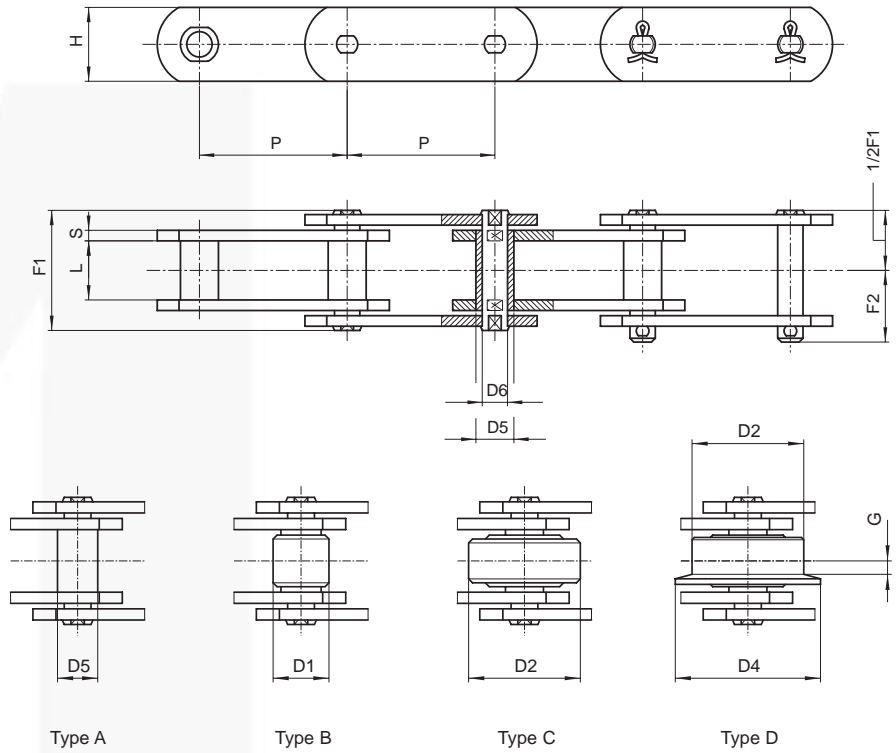

SOLID PIN CHAINS

Chain N.	P mm	L mm	D1 mm	D2 mm	D4 mm	G mm	D5 mm	D6 mm	H mm	S mm	F1 mm	F2 mm	Breaking load	
													N	N*
M 20	40	16	12,5	25	32	3,5	9	6	18	2,5	33	19	20.000	32.000
"	50	"	"	"	"	"	"	"	"	"	"	"	"	"
"	63	"	"	"	"	"	"	"	"	"	"	"	"	"
"	80	"	"	"	"	"	"	"	"	"	"	"	"	"
M 28	50	18	15	30	36	4	10	7	20	3	36	20,5	28.000	42.000
"	63	"	"	"	"	"	"	"	"	"	"	"	"	"
"	80	"	"	"	"	"	"	"	"	"	"	"	"	"
"	100	"	"	"	"	"	"	"	"	"	"	"	"	"
M 40	63	20	18	36	45	4,5	11	8	25	4	40,5	24	40.000	60.000
"	80	"	"	"	"	"	"	"	"	"	"	"	"	"
"	100	"	"	"	"	"	"	"	"	"	"	"	"	"
"	125	"	"	"	"	"	"	"	"	"	"	"	"	"
M 56	63	24	21	42	50	7	15	10	30	4	45	26	56.000	85.000
"	80	"	"	"	"	"	"	"	"	"	"	"	"	"
"	100	"	"	"	"	"	"	"	"	"	"	"	"	"
"	125	"	"	"	"	"	"	"	"	"	"	"	"	"
"	160	"	"	"	"	"	"	"	"	"	"	"	"	"
M 80	80	28	25	50	60	7	18	12	35	5	54,5	30,5	80.000	125.000
"	100	"	"	"	"	"	"	"	"	"	"	"	"	"
"	125	"	"	"	"	"	"	"	"	"	"	"	"	"
"	160	"	"	"	"	"	"	"	"	"	"	"	"	"
"	200	"	"	"	"	"	"	"	"	"	"	"	"	"

(*) Breaking load with heat treated plates

- Additional features:
- rollers of nylon, delrin, etc.
 - with extended pins
 - in STAINLESS steel
 - surface treatments of zinc plating, nickel plating, etc.
 - pre-tensioned and labelled



METRIC CHAINS, ISO 1977 – DIN 8167

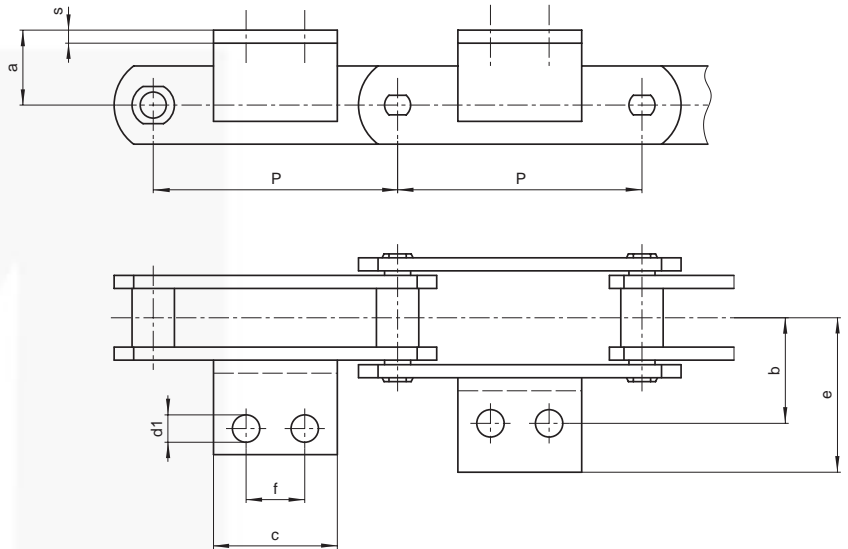

Layout of attachments
on page 1.9/2

ATTACHMENTS

Chain N.	P mm	a mm	b mm	c mm	d1 mm	e mm	f mm	Angle mm	Chain weight Kg/mt				Weight per attach. kg
									type A	type B	type C	type D	
M 20	40	16	27	14	6,6	40	●	*	1,1	1,3	2,4	2,5	0,020
"	50	"	"	14	"	"	●	*	1,01	1,3	2	2,1	0,020
"	63	"	"	35	"	"	●	25x3	0,99	1,2	1,8	1,9	0,040
"	80	"	"	50	"	"	●	35	0,9	1,1	1,6	1,6	0,060
M28	50	20	32	20	9	47	●	20x3	1,6	1,9	3,3	3,4	0,020
"	63	"	"	20	"	"	●	30x3	1,5	1,7	2,8	2,9	0,020
"	80	"	"	45	"	"	●	25	1,4	1,6	2,5	2,6	0,050
"	100	"	"	60	"	"	●	40	1,3	1,5	2,1	2,2	0,080
M 40	63	25	35	31	9	50	●	* 30x4	2,25	2,6	4,4	4,6	0,040
"	80	"	"	45	"	"	●	* "	2	2,3	3,7	3,9	0,070
"	100	"	"	60	"	"	●	* "	1,9	2,1	3,2	3,4	0,100
"	125	"	"	85	"	"	●	"	1,8	2	2,9	3	0,150
M 56	63	30	44	22	11	61	●	40x4	3,4	3,9	6,8	7,2	0,050
"	80	"	"	30	"	"	●	"	3	3,4	5,7	6	0,070
"	100	"	"	50	"	"	●	25	2,8	3,1	5	5,2	0,120
"	125	"	"	75	"	"	●	50	2,6	2,9	4,4	4,5	0,180
"	160	"	"	110	"	"	●	85	2,54	2,7	3,9	4,1	0,270
M 80	80	35	48	30	11	65	●	* 40x4	4,7	5,4	9,2	9,4	0,070
"	100	"	"	50	"	"	●	* "	4,3	4,8	7,9	8	0,120
"	125	"	"	75	"	"	●	* "	4	4,4	6,9	7	0,180
"	160	"	"	110	"	"	●	* "	3,7	4	6	6,1	0,270
"	200	"	"	150	"	"	●	* "	3,5	3,8	5,3	5,4	0,360

● attachments with 1 hole
* as alternative integral attachments

All attachments can be with one hole



METRIC CHAINS, ISO 1977 – DIN 8167

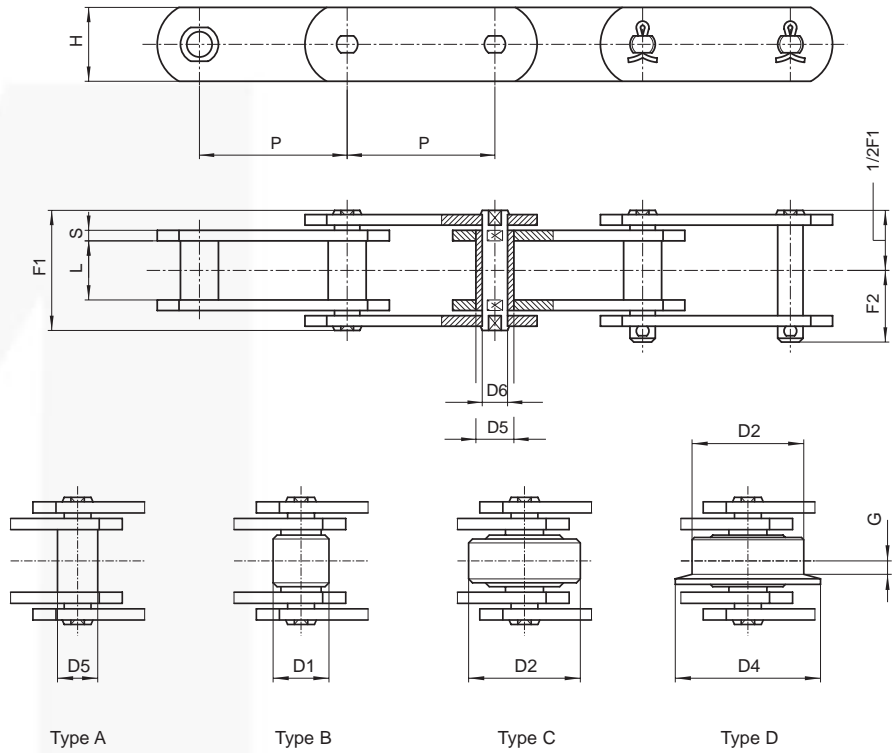

SOLID PIN CHAINS

Chain N.	P mm	L mm	D1 mm	D2 mm	D4 mm	G mm	D5 mm	D6 mm	H mm	S mm	F1 mm	F2 mm	Breaking load	
													N	N*
M 112	80	32	30	60	75	7,5	21	15	40	6	63	36	112.000	175.000
"	100	"	"	"	"	"	"	"	"	"	"	"	"	"
"	125	"	"	"	"	"	"	"	"	"	"	"	"	"
"	160	"	"	"	"	"	"	"	"	"	"	"	"	"
"	200	"	"	"	"	"	"	"	"	"	"	"	"	"
M 160	100	37	36	70	90	8,5	25	18	50	7	72	41,5	160.000	260.000
"	125	"	"	"	"	"	"	"	"	"	"	"	"	"
"	160	"	"	"	"	"	"	"	"	"	"	"	"	"
"	200	"	"	"	"	"	"	"	"	"	"	"	"	"
"	250	"	"	"	"	"	"	"	"	"	"	"	"	"
M 224	125	43	42	85	105	10	30	21	60	8	84	47	224.000	340.000
"	160	"	"	"	"	"	"	"	"	"	"	"	"	"
"	200	"	"	"	"	"	"	"	"	"	"	"	"	"
"	250	"	"	"	"	"	"	"	"	"	"	"	"	"
"	315	"	"	"	"	"	"	"	"	"	"	"	"	"
M 315	160	48	50	100	124	10,5	36	25	70	10	97	55	315.000	520.000
"	200	"	"	"	"	"	"	"	"	"	"	"	"	"
"	250	"	"	"	"	"	"	"	"	"	"	"	"	"
"	315	"	"	"	"	"	"	"	"	"	"	"	"	"
"	400	"	"	"	"	"	"	"	"	"	"	"	"	"

(*) Breaking load with heat treated plates

- Additional features:
- rollers of nylon, delrin, etc.
 - with extended pins
 - in STAINLESS steel
 - surface treatments of zinc plating, nickel plating, etc.
 - pre-tensioned and labelled



METRIC CHAINS, ISO 1977 – DIN 8167

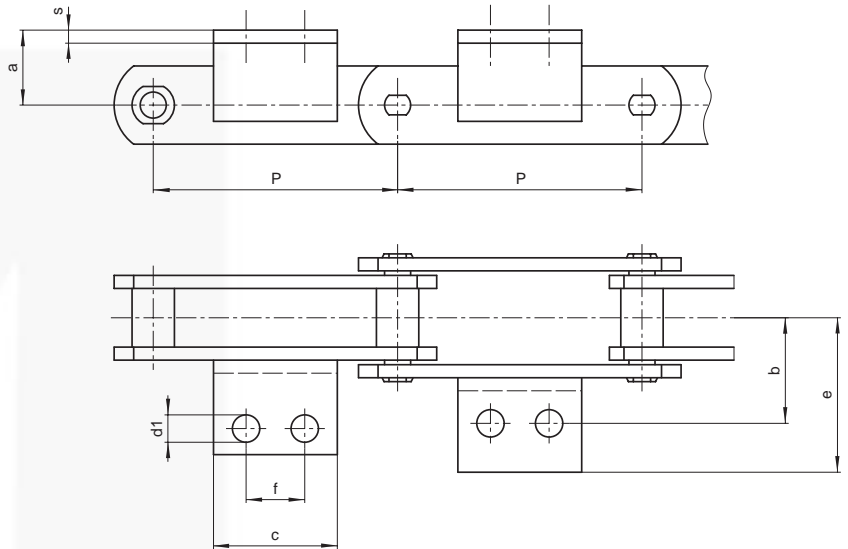

Layout of attachments
on page 1.9/2

ATTACHMENTS

Chain N.	P mm	a mm	b mm	c mm	d1 mm	e mm	f mm	Angle mm	Chain weight Kg/mt				Weight per attach. kg
									type A	type B	type C	type D	
M 112	80	40	55	28	14	80	●	50x6	6,8	8	14	14,7	0,130
"	100	"	"	40	"	"	●	"	6,2	7,2	12	12,5	0,180
"	125	"	"	65	"	"	35	"	5,7	6,5	10,4	10,8	0,300
"	160	"	"	95	"	"	65	"	5,3	5,9	9	9,3	0,440
"	200	"	"	130	"	"	100	"	5	5,5	7,9	8,2	0,590
M 160	100	45	62	30	14	85	●	50x6	9,7	11,2	18,9	20,2	0,130
"	125	"	"	50	"	"	25	"	8,9	10	16,3	18,1	0,230
"	160	"	"	80	"	"	50	"	8,2	9,1	14	15,4	0,370
"	200	"	"	115	"	"	85	"	7,6	8,4	12,2	13,4	0,530
"	250	"	"	175	"	"	145	"	7,3	7,9	11	12	0,800
M 224	125	55	70	35	18	100	●	60x8	13	14,8	25,8	26,6	0,300
"	160	"	"	60	"	"	●	"	12	13,4	22	22,7	0,430
"	200	"	"	100	"	"	65	"	11	12,1	19	19,5	0,710
"	250	"	"	160	"	"	125	"	10,3	11,2	16,7	17,1	1,130
"	315	"	"	230	"	"	190	"	9,8	10,5	14,9	15,2	1,600
M 315	160	65	80	35	18	115	●	70x9	18,3	20,4	33,3	34,6	0,320
"	200	"	"	85	"	"	50	"	16,7	18,4	28,7	29,7	0,660
"	250	"	"	140	"	"	100	"	15,6	17	25,2	26	1,100
"	315	"	"	190	"	"	155	"	14,6	15,7	22,3	22,9	1,460
"	400	"	"	205	"	"	155	"	13,9	14,8	20	20,5	1,460

● attachments with 1 hole
All attachments can be with one hole



METRIC CHAINS, ISO 1977 – DIN 8167

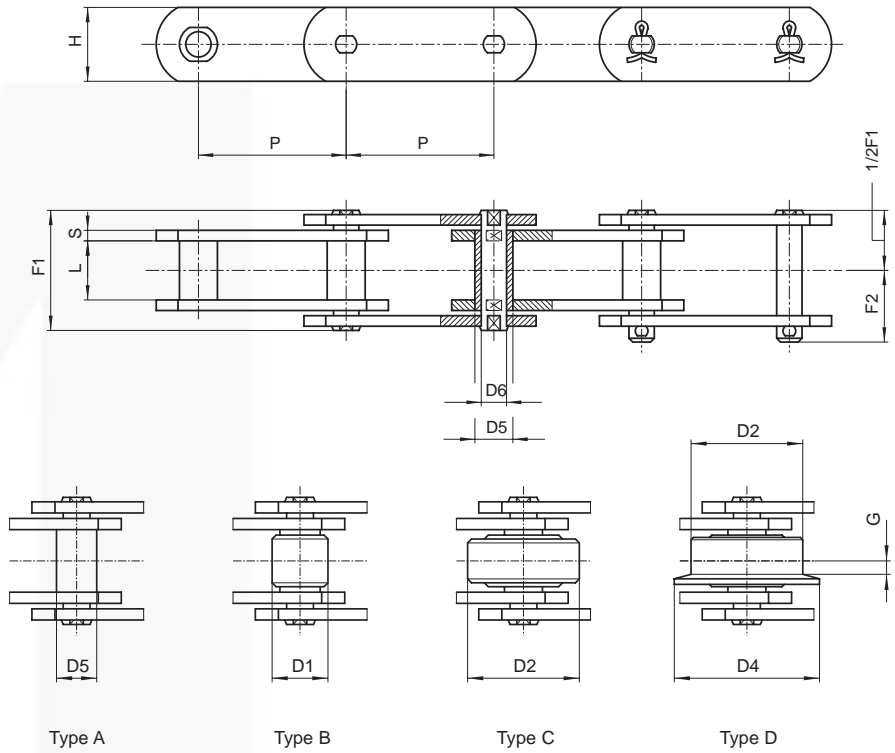

SOLID PIN CHAINS

Chain N.	P mm	L mm	D1 mm	D2 mm	D4 mm	G mm	D5 mm	D6 mm	H mm	S mm	F1 mm	F2 mm	Breaking load	
													N	N*
M 450	200	56	60	120	149	11,5	42	30	80	12	114	67	450.000	700.000
"	250	"	"	"	"	"	"	"	"	"	"	"	"	"
"	315	"	"	"	"	"	"	"	"	"	"	"	"	"
"	400	"	"	"	"	"	"	"	"	"	"	"	"	"
M 630	250	67	70	140	170	15	50	36	100	14	137	87,5	630.000	900.000
"	315	"	"	"	"	"	"	"	"	"	"	"	"	"
"	400	"	"	"	"	"	"	"	"	"	"	"	"	"
"	500	"	"	"	"	"	"	"	"	"	"	"	"	"
M 900	250	78	85	170	210	17	60	44	120	16	153	95	900.000	1.250.000
"	315	"	"	"	"	"	"	"	"	"	"	"	"	"
"	400	"	"	"	"	"	"	"	"	"	"	"	"	"
"	500	"	"	"	"	"	"	"	"	"	"	"	"	"
"	600	"	"	"	"	"	"	"	"	"	"	"	"	"

(*) Breaking load with heat treated plates

- Additional features:
- rollers of nylon, delrin, etc.
 - with extended pins
 - in STAINLESS steel
 - surface treatments of zinc plating, nickel plating, etc.
 - pre-tensioned and labelled



METRIC CHAINS, ISO 1977 – DIN 8167

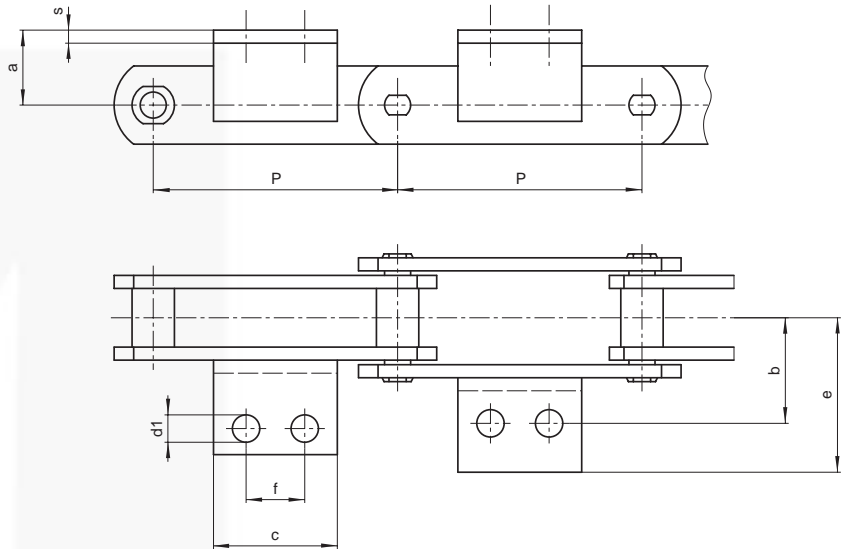

Layout of attachments
on page 1.9/2

ATTACHMENTS

Chain N.	P mm	a mm	b mm	c mm	d1 mm	e mm	f mm	Angle mm	Chain weight Kg/mt				Weight per attach. kg
									type A	type B	type C	type D	
M 450	200	75	90	50	18	125	●	70x9	24	27	40,5	47	0,330
"	250	"	"	125	"	"	85	"	22	24,9	39,5	41	1,000
"	315	"	"	195	"	"	155	"	21	23	34,5	36	1,600
"	400	"	"	280	"	"	240	"	19,6	21,2	30,5	31,4	2,300
M 630	250	90	115	50	24	165	●	100x12	36	40,8	64	66,9	0,900
"	315	"	"	150	"	"	100	"	33,4	36,6	55,5	57,7	2,700
"	400	"	"	240	"	"	190	"	31,5	33,9	49	50,7	4,300
"	500	"	"	350	"	"	300	"	29,6	31,6	43,6	45	6,200
M 900	250	110	140	60	30	195	●	120x15	49,7	56,5	98,3	104,5	1,600
"	315	"	"	125	"	"	65	"	45,5	51,8	84,2	89,7	3,300
"	400	"	"	215	"	"	155	"	42	46,2	72,5	76,9	5,700
"	500	"	"	300	"	"	240	"	39,3	42,7	63,8	67,6	8,000
"	600	"	"	350	"	"	300	"	37,3	39,9	56,6	58,9	8,000

● attachments with 1 hole
All attachments can be with one hole



METRIC CHAINS, ISO 1977 – DIN 8167

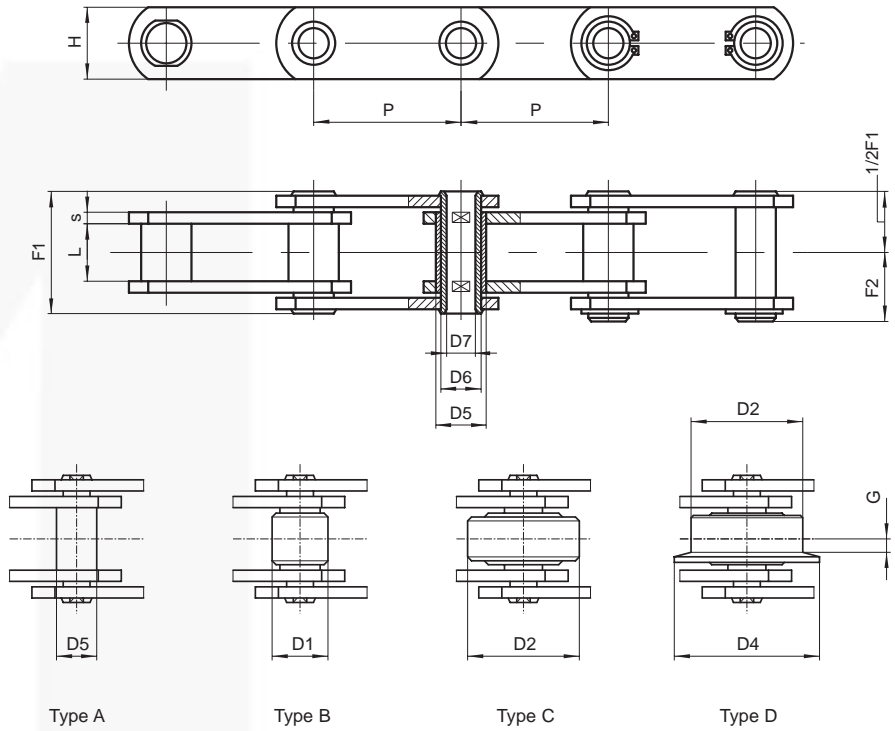

HOLLOW PIN CHAINS

Chain N.	P mm	L mm	D1 mm	D2 mm	D4 mm	G mm	D5 mm	D6 mm	D7 mm	H mm	S mm	F1 mm	F2 mm	Breaking load		Weight per attach. kg/m**
														N	N*	
MC 28	50	20	25	36	45	4,5	17	13	8,2	25	3	36	20,5	28.000	40.000	4,3
"	63	"	"	"	"	"	"	"	"	"	"	"	"	"	"	3,8
"	80	"	"	"	"	"	"	"	"	"	"	"	"	"	"	3,2
"	100	"	"	"	"	"	"	"	"	"	"	"	"	"	"	2,8
"	125	"	"	"	"	"	"	"	"	"	"	"	"	"	"	2,5
MC 56	63	24	30	50	60	7	21	15,5	10,2	35	4	45	25	56.000	90.000	8,5
"	80	"	"	"	"	"	"	"	"	"	"	"	"	"	"	7,2
"	100	"	"	"	"	"	"	"	"	"	"	"	"	"	"	6,2
"	125	"	"	"	"	"	"	"	"	"	"	"	"	"	"	5,4
"	160	"	"	"	"	"	"	"	"	"	"	"	"	"	"	4,7
MC 112	80	32	42	70	85	8,5	29	22	14,3	50	6	62,5	33	112.000	180.000	16,6
"	100	"	"	"	"	"	"	"	"	"	"	"	"	"	"	14
"	125	"	"	"	"	"	"	"	"	"	"	"	"	"	"	11,2
"	160	"	"	"	"	"	"	"	"	"	"	"	"	"	"	10,2
"	200	"	"	"	"	"	"	"	"	"	"	"	"	"	"	8,9
"	250	"	"	"	"	"	"	"	"	"	"	"	"	"	"	7,9
MC 224	125	43	60	100	120	10,5	42	30	20,3	70	8	83	44	224.000	350.000	32,3
"	160	"	"	"	"	"	"	"	"	"	"	"	"	"	"	27,1
"	200	"	"	"	"	"	"	"	"	"	"	"	"	"	"	23,5
"	250	"	"	"	"	"	"	"	"	"	"	"	"	"	"	20,6
"	315	"	"	"	"	"	"	"	"	"	"	"	"	"	"	17,2

(*) Breaking load with heat treated plates

(**) Weight for chain with roller "Type C"

Additional features:

- rollers of nylon, delrin, etc.
- in STAINLESS steel
- surface treatments of zinc plating, nickel plating, etc.
- pre-tensioned and labelled

METRIC CHAINS, ISO 1977 – DIN 8167

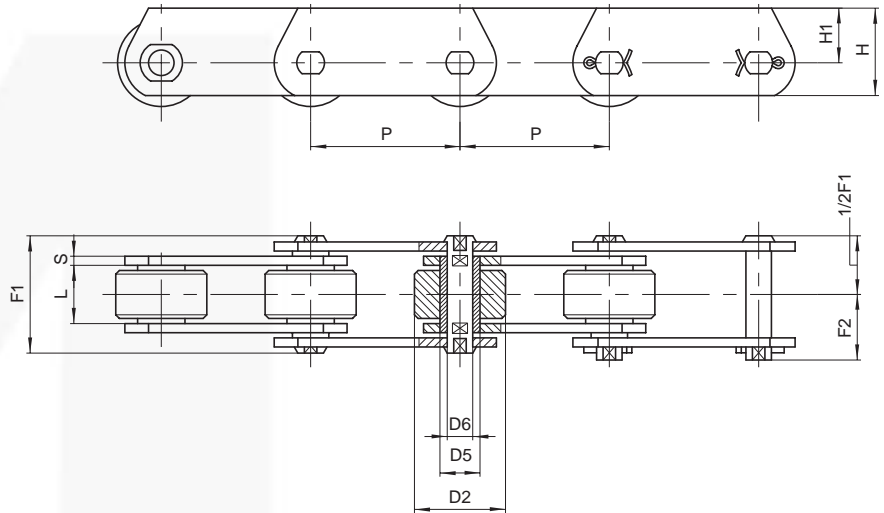

DEEP LINK CHAINS

Chain N.	P mm	L mm	D2 mm	D5 mm	D6 mm	H mm	H1 mm	S mm	F1 mm	F2 mm	Breaking load		Chain weight kg/m
											N	N*	
ME 20	40	16	25	9	6	25	16	2,5	33	19	20.000	32.000	3
"	50	"	"	"	"	"	"	"	"	"	"	"	2,6
"	63	"	"	"	"	"	"	"	"	"	"	"	2,3
"	80	"	"	"	"	"	"	"	"	"	"	"	2
ME 28	50	18	30	10	7	30	20	3	36	20,5	28.000	42.000	4,1
"	63	"	"	"	"	"	"	"	"	"	"	"	3,5
"	80	"	"	"	"	"	"	"	"	"	"	"	3,1
"	100	"	"	"	"	"	"	"	"	"	"	"	2,8
ME 40	63	20	36	11	8	35	22,5	4	40,5	24	40.000	60.000	5,5
"	80	"	"	"	"	"	"	"	"	"	"	"	4,8
"	100	"	"	"	"	"	"	"	"	"	"	"	4,2
"	125	"	"	"	"	"	"	"	"	"	"	"	3,7
ME 56	63	24	42	15	10	45	30	4	45	26	56.000	85.000	8,3
"	80	"	"	"	"	"	"	"	"	"	"	"	7
"	100	"	"	"	"	"	"	"	"	"	"	"	6,1
"	125	"	"	"	"	"	"	"	"	"	"	"	5,4
ME 80	80	28	50	18	12	50	32,5	5	54,5	30,5	80.000	125.000	11
"	100	"	"	"	"	"	"	"	"	"	"	"	9,5
"	125	"	"	"	"	"	"	"	"	"	"	"	8,5
"	160	"	"	"	"	"	"	"	"	"	"	"	7,2
"	200	"	"	"	"	"	"	"	"	"	"	"	6

(*) Breaking load with heat treated plates

Additional features:

- rollers of nylon, delrin, etc.
- in STAINLESS steel
- surface treatments of zinc plating, nickel plating, etc.
- pre-tensioned and labelled



METRIC CHAINS, ISO 1977 – DIN 8167

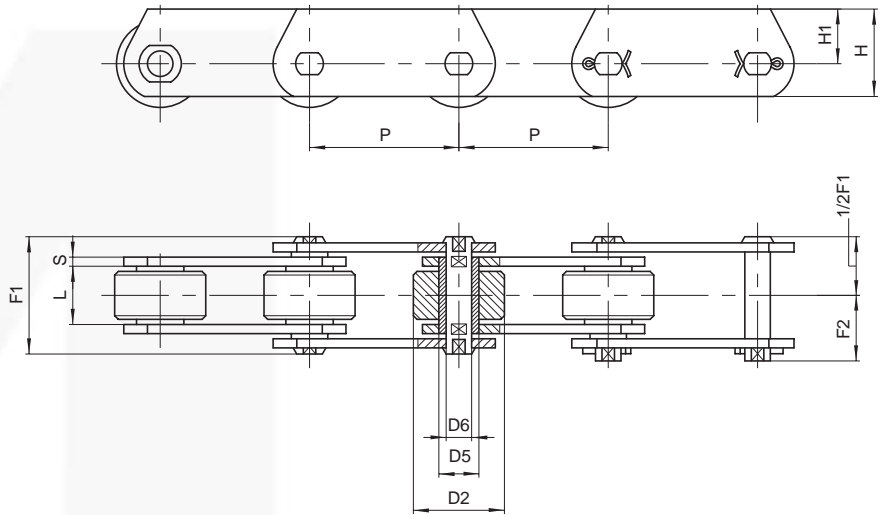

DEEP LINK CHAINS

Chain N.	P mm	L mm	D2 mm	D5 mm	D6 mm	H mm	H1 mm	S mm	F1 mm	F2 mm	Breaking load		Chain weight kg/m
											N	N*	
ME 112	80	32	60	21	15	60	40	6	63	36	112.000	175.000	17
"	100	"	"	"	"	"	"	"	"	"	"	"	14,5
"	125	"	"	"	"	"	"	"	"	"	"	"	13
"	160	"	"	"	"	"	"	"	"	"	"	"	11
"	200	"	"	"	"	"	"	"	"	"	"	"	10
ME 160	100	37	70	25	18	70	45	7	72	41,5	160.000	260.000	21,5
"	125	"	"	"	"	"	"	"	"	"	"	"	19
"	160	"	"	"	"	"	"	"	"	"	"	"	17
"	200	"	"	"	"	"	"	"	"	"	"	"	15
"	250	"	"	"	"	"	"	"	"	"	"	"	13,5
ME 224	125	43	85	30	21	90	60	8	84	47	224.000	340.000	32,5
"	160	"	"	"	"	"	"	"	"	"	"	"	27,5
"	200	"	"	"	"	"	"	"	"	"	"	"	23
"	250	"	"	"	"	"	"	"	"	"	"	"	21
"	315	"	"	"	"	"	"	"	"	"	"	"	19
ME 315	160	48	100	36	25	100	65	10	97	55	315.000	520.000	43
"	200	"	"	"	"	"	"	"	"	"	"	"	37
"	250	"	"	"	"	"	"	"	"	"	"	"	32
"	315	"	"	"	"	"	"	"	"	"	"	"	28,6
"	400	"	"	"	"	"	"	"	"	"	"	"	25,5

(*) Breaking load with heat treated plates

- Additional features:
- rollers of nylon, delrin, etc.
 - in STAINLESS steel
 - surface treatments of zinc plating, nickel plating, etc.
 - pre-tensioned and labelled



METRIC CHAINS, ISO 1977 – DIN 8167

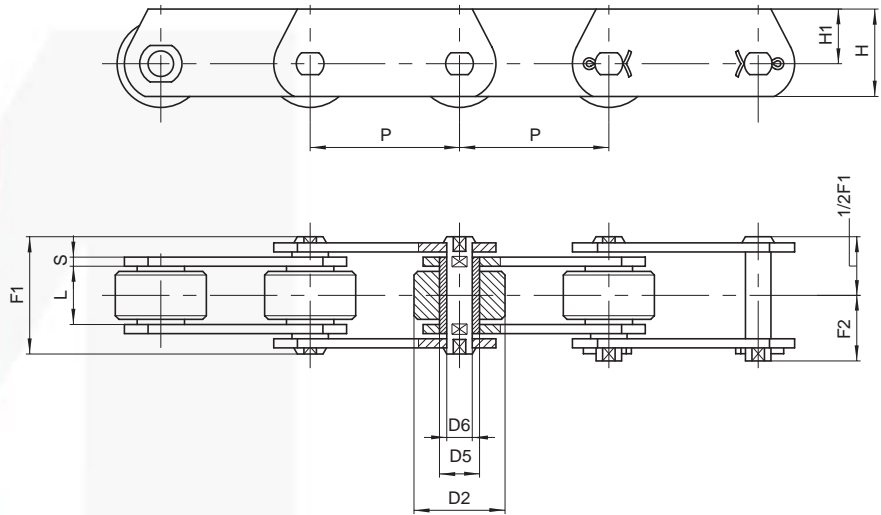

DEEP LINK CHAINS

Chain N.	P mm	L mm	D2 mm	D5 mm	D6 mm	H mm	H1 mm	S mm	F1 mm	F2 mm	Breaking load		Chain weight kg/m
											N	N*	
ME 450	200	56	120	42	30	120	80	12	114	67	450.000	700.000	47
"	250	"	"	"	"	"	"	"	"	"	"	"	41
"	315	"	"	"	"	"	"	"	"	"	"	"	36
"	400	"	"	"	"	"	"	"	"	"	"	"	32
ME 630	250	66	140	50	36	140	90	14	137	87,5	630.000	900.000	71
"	315	"	"	"	"	"	"	"	"	"	"	"	62,5
"	400	"	"	"	"	"	"	"	"	"	"	"	56
"	500	"	"	"	"	"	"	"	"	"	"	"	50,6
"	600	"	"	"	"	"	"	"	"	"	"	"	46,5
ME 900	250	78	170	60	44	180	120	16	153	95	900.000	1.250.000	108,5
"	315	"	"	"	"	"	"	"	"	"	"	"	94,5
"	400	"	"	"	"	"	"	"	"	"	"	"	82,5
"	500	"	"	"	"	"	"	"	"	"	"	"	73,8
"	600	"	"	"	"	"	"	"	"	"	"	"	66,7

(*) Breaking load with heat treated plates

Additional features:

- rollers of nylon, delrin, etc.
- in STAINLESS steel
- surface treatments of zinc plating, nickel plating, etc.
- pre-tensioned and labelled





Series

METRIC CHAINS, DIN 8165 (C series)



METRIC CHAINS, DIN 8165

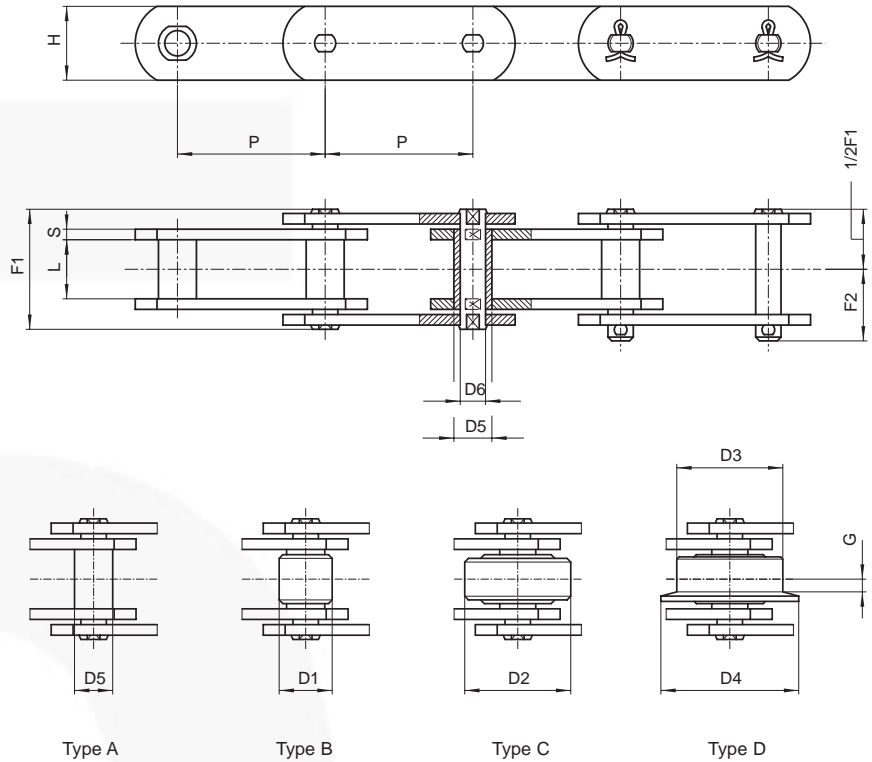

SOLID PIN CHAINS

DIN N.	Chain N.	P mm	L mm	D1 mm	D2 mm	D3 mm	D4 mm	G mm	D5 mm	D6 mm	H mm	S mm	F1 mm	F2 mm	Breaking load N N*	
FV40	C 42	50	18	20	32	40	50	4	15	10	25	3	36	21	42.000	47.000
"	"	63	"	"	"	"	"	"	"	"	"	"	"	"	"	"
"	"	80	"	"	"	"	"	"	"	"	"	"	"	"	"	"
"	"	100	"	"	"	"	"	"	"	"	"	"	"	"	"	"
"	"	125	"	"	"	"	"	"	"	"	"	"	"	"	"	"
FV63	C 64	63	22	26	40	50	63	5	18	12	30	4	45	26	64.000	75.000
"	"	80	"	"	"	"	"	"	"	"	"	"	"	"	"	"
"	"	100	"	"	"	"	"	"	"	"	"	"	"	"	"	"
"	"	125	"	"	"	"	"	"	"	"	"	"	"	"	"	"
"	"	160	"	"	"	"	"	"	"	"	"	"	"	"	"	"
FV90	C 100	63	25	30	48	63	78	6,5	20	14	35	5	53	30	100.000	115.000
"	"	80	"	"	"	"	"	"	"	"	"	"	"	"	"	"
"	"	100	"	"	"	"	"	"	"	"	"	"	"	"	"	"
"	"	125	"	"	"	"	"	"	"	"	"	"	"	"	"	"
"	"	160	"	"	"	"	"	"	"	"	"	"	"	"	"	"
"	"	200	"	"	"	"	"	"	"	"	"	"	"	"	"	"
"	"	250	"	"	"	"	"	"	"	"	"	"	"	"	"	"
FV112	C 120	100	30	32	55	72	90	7,5	22	16	40	6	62	35	120.000	170.000
"	"	125	"	"	"	"	"	"	"	"	"	"	"	"	"	"
"	"	160	"	"	"	"	"	"	"	"	"	"	"	"	"	"
"	"	200	"	"	"	"	"	"	"	"	"	"	"	"	"	"
"	"	250	"	"	"	"	"	"	"	"	"	"	"	"	"	"

(*) Breaking load with heat treated plates

- Additional features:
- rollers of nylon, delrin, etc.
 - with extended pins
 - in STAINLESS steel
 - surface treatments of zinc plating, nickel plating, etc.
 - pre-tensioned and labelled



METRIC CHAINS, DIN 8165

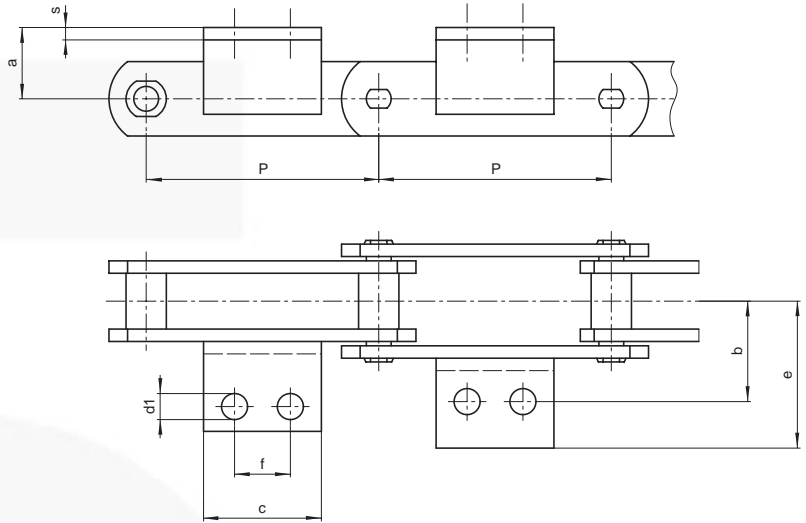

Layout of attachments
on page 1.9/2

ATTACHMENTS

DIN N.	Chain N.	P mm	a mm	b mm	c mm	d1 mm	e mm	f mm	Angle mm	Chain weight Kg/mt				Weight per attach.
										type A	type B	type C	type D	
FV40	C 42	50	20	25	45	6,5	64	●	*	2,4	2,9	4	5,6	0,050
"	"	63	"	"	31	"	40,5	●	*	2	2,4	3,3	4,5	0,036
"	"	80	"	"	45	"	"	25	* 25x3	1,9	2,2	3	3,9	0,050
"	"	100	"	"	50	"	"	30	* "	1,7	2	2,6	3,3	0,056
"	"	125	"	"	60	"	"	30	* "	1,6	1,9	2,3	3	0,067
FV63	C 64	63	30	34	40	8,4	50	●	30x4	3,8	4,5	6,4	8,9	0,063
"	"	80	"	"	45	"	"	25	* "	3,2	3,8	5,3	7,2	0,095
"	"	100	"	"	50	"	"	30	"	3	3,5	4,7	6,2	0,110
"	"	125	"	"	60	"	"	40	"	2,7	3	4	5,3	0,140
"	"	160	"	"	70	"	"	50	"	2,4	2,7	3,5	4,4	0,170
FV90	C 100	63	35	40	30	8,4	64	●	* 40x4	5,6	6,8	10	14,7	0,072
"	"	80	"	"	45	"	"	25	* "	5,1	6	8,6	12,3	0,110
"	"	100	"	"	50	"	"	30	* "	4,5	5,3	7,3	10,3	0,130
"	"	125	"	"	60	"	"	40	* "	4,2	4,8	6,5	8,8	0,160
"	"	160	"	"	70	"	"	50	* "	4	4,5	5,8	7,6	0,200
"	"	200	"	"	80	"	"	60	* "	3,5	3,8	4,8	5,8	0,240
"	"	250	"	"	85	"	"	65	* "	3,4	3,7	4,6	5,4	0,210
FV112	C 120	100	40	50	50	11	70	30	40x6	6,7	7,7	11,2	18,8	0,200
"	"	125	"	"	65	"	"	40	"	6	6,8	9,6	15,7	0,270
"	"	160	"	"	75	"	"	50	"	5,5	6,1	8,3	13	0,310
"	"	200	"	"	90	"	"	65	"	5,2	5,7	7,5	11,3	0,400
"	"	250	"	"	105	"	"	80	"	4,9	5,3	6,7	9,8	0,500

● attachments with 1 hole
* integral attachments



METRIC CHAINS, DIN 8165

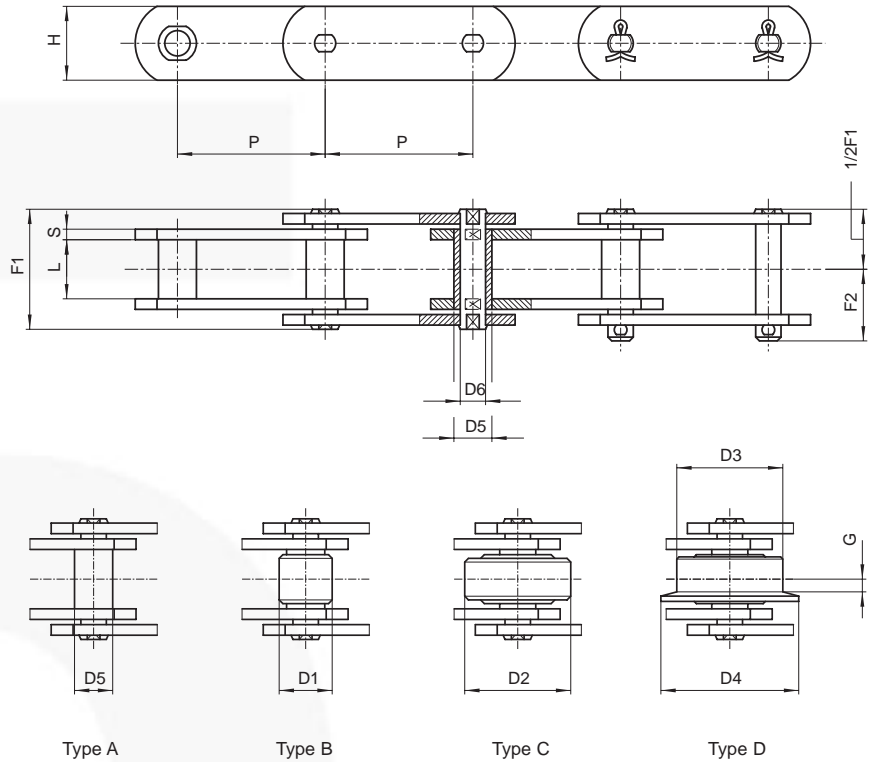

SOLID PIN CHAINS

DIN N.	Chain N.	P mm	L mm	D1 mm	D2 mm	D3 mm	D4 mm	G mm	D5 mm	D6 mm	H mm	S mm	F1 mm	F2 mm	Breaking load N N*	
FV140	C 145	100	35	36	60	80	100	9	26	18	45	6	67	38	145.000	180.000
"	"	125	"	"	"	"	"	"	"	"	"	"	"	"	"	"
"	"	160	"	"	"	"	"	"	"	"	"	"	"	"	"	"
"	"	200	"	"	"	"	"	"	"	"	"	"	"	"	"	"
"	"	250	"	"	"	"	"	"	"	"	"	"	"	"	"	"
FV180	C 190	125	45	42	70	100	125	13	30	20	50	8	86	49	190.000	250.000
"	"	160	"	"	"	"	"	"	"	"	"	"	"	"	"	"
"	"	200	"	"	"	"	"	"	"	"	"	"	"	"	"	"
"	"	250	"	"	"	"	"	"	"	"	"	"	"	"	"	"
"	"	315	"	"	"	"	"	"	"	"	"	"	"	"	"	"
FV250	C 275	160	55	50	80	125	155	15	36	26	60	8	97	55	275.000	300.000
"	"	200	"	"	"	"	"	"	"	"	"	"	"	"	"	"
"	"	250	"	"	"	"	"	"	"	"	"	"	"	"	"	"
"	"	315	"	"	"	"	"	"	"	"	"	"	"	"	"	"
"	"	400	"	"	"	"	"	"	"	"	"	"	"	"	"	"
FV315	C 370	160	65	60	90	140	175	18	42	30	70	10	113	70	370.000	480.000
"	"	200	"	"	"	"	"	"	"	"	"	"	"	"	"	"
"	"	250	"	"	"	"	"	"	"	"	"	"	"	"	"	"
"	"	315	"	"	"	"	"	"	"	"	"	"	"	"	"	"
"	"	400	"	"	"	"	"	"	"	"	"	"	"	"	"	"

(*) Breaking load with heat treated plates

- Additional features:
- rollers of nylon, delrin, etc.
 - with extended pins
 - in STAINLESS steel
 - surface treatments of zinc plating, nickel plating, etc.
 - pre-tensioned and labelled



METRIC CHAINS, DIN 8165

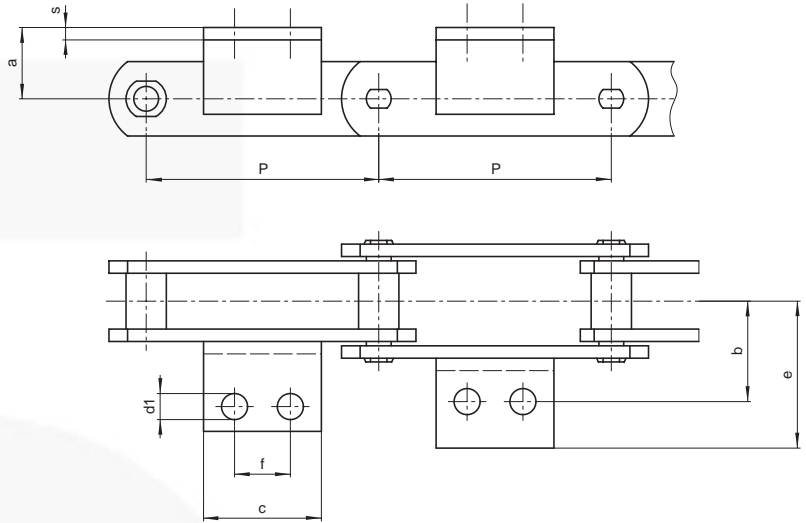

Layout of attachments
on page 1.9/2

ATTACHMENTS

DIN N.	Chain N.	P mm	a mm	b mm	c mm	d1 mm	e mm	f mm	Angle mm	Chain weight Kg/mt				Weight per attach. kg
										type A	type B	type C	type D	
FV140	C 145	100	45	50	55	11	81	30	50x6	8,2	9,5	14,3	21,4	0,230
"	"	125	"	"	65	"	"	40	"	7,4	8,5	12,3	18	0,300
"	"	160	"	"	75	"	"	50	"	6,7	7,5	10,5	14,9	0,360
"	"	200	"	"	90	"	"	65	"	6	6,7	9	12,8	0,450
"	"	250	"	"	105	"	"	80	"	5,8	6,3	8,3	11	0,540
FV180	C 190	125	45	64	63	13	91	35	50x7	10,5	12,4	18,9	31,3	0,320
"	"	160	"	"	80	"	"	50	"	10,2	11,7	16,7	26,5	0,410
"	"	200	"	"	95	"	"	65	"	9,6	10,8	14,8	25,9	0,520
"	"	250	"	"	110	"	"	80	"	8,9	9,8	13	19,3	0,620
"	"	315	"	"	130	"	"	100	"	8,3	9	11,6	16,6	0,720
FV250	C 275	160	55	69	80	14	106	50	60x8	13,4	16,4	23,8	45,9	0,570
"	"	200	"	"	95	"	"	65	"	12,3	14,7	20,6	38,3	0,710
"	"	250	"	"	110	"	"	80	"	11,3	13,3	17,9	32,1	0,850
"	"	315	"	"	130	"	"	100	"	10,5	12	15,8	27	1,000
"	"	400	"	"	130	"	"	100	"	9,8	10,7	13,9	23,8	1,000
FV315	C 370	160	60	85	50	14	130	●	70x10	20,4	24,9	33,3	67,8	0,520
"	"	200	"	"	95	"	"	65	"	18,5	22,1	28,9	56,4	0,980
"	"	250	"	"	110	"	"	80	"	17	20	25,3	47,3	1,130
"	"	315	"	"	130	"	"	100	"	15,9	18,2	22,4	39,9	1,340
"	"	400	"	"	130	"	"	100	"	15	16,8	20,2	34	1,340

● attachments with 1 hole



METRIC CHAINS, DIN 8165

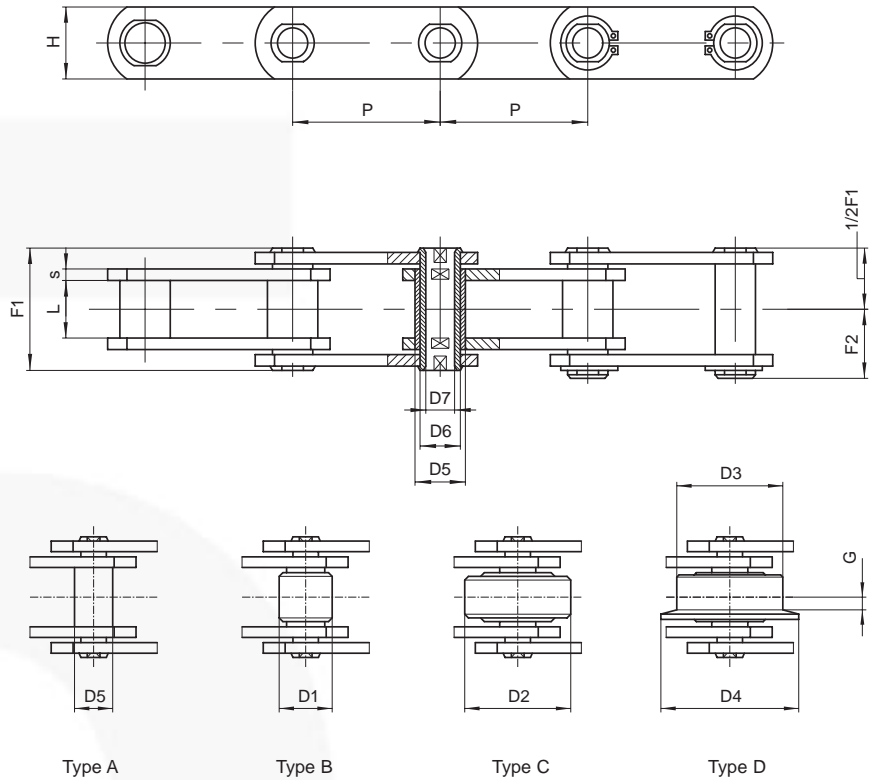

HOLLOW PIN CHAINS

DIN N.	Chain N.	P mm	L mm	D1 mm	D2 mm	D3 mm	D4 mm	G mm	D5 mm	D6 mm	D7 mm	H mm	S mm	F1 mm	F2 mm	Breaking load N	Chain weight kg/m ^{**}
FV63	CC 46	63	22	26	40	50	63	5	18	12	8	30	4	45	28	46.000	5,7
"	"	80	"	"	"	"	"	"	"	"	"	"	"	"	"	"	4,9
"	"	100	"	"	"	"	"	"	"	"	"	"	"	"	"	"	4,3
"	"	125	"	"	"	"	"	"	"	"	"	"	"	"	"	"	3,8
"	"	160	"	"	"	"	"	"	"	"	"	"	"	"	"	"	3,4
FV90	CC 73	63	25	30	48	63	78	6,5	20	14	10	35	5	53	30	73.000	9,1
"	"	80	"	"	"	"	"	"	"	"	"	"	"	"	"	"	7,8
"	"	100	"	"	"	"	"	"	"	"	"	"	"	"	"	"	6,8
"	"	125	"	"	"	"	"	"	"	"	"	"	"	"	"	"	5,6
"	"	160	"	"	"	"	"	"	"	"	"	"	"	"	"	"	5,3
"	"	200	"	"	"	"	"	"	"	"	"	"	"	"	"	"	4,7
"	"	250	"	"	"	"	"	"	"	"	"	"	"	"	"	"	4,3
FV112	CC 90	100	30	32	55	72	90	7,5	22	16	11	40	6	62	32	90.000	10,2
"	"	125	"	"	"	"	"	"	"	"	"	"	"	"	"	"	8,9
"	"	160	"	"	"	"	"	"	"	"	"	"	"	"	"	"	7,8
"	"	200	"	"	"	"	"	"	"	"	"	"	"	"	"	"	7
"	"	250	"	"	"	"	"	"	"	"	"	"	"	"	"	"	6,3
FV140	CC 110	100	35	36	60	80	100	9	26	18	12	45	6	67	35	110.000	12,9
"	"	125	"	"	"	"	"	"	"	"	"	"	"	"	"	"	11,2
"	"	160	"	"	"	"	"	"	"	"	"	"	"	"	"	"	9,7
"	"	200	"	"	"	"	"	"	"	"	"	"	"	"	"	"	8,6
"	"	250	"	"	"	"	"	"	"	"	"	"	"	"	"	"	7,7

(*) Breaking load with heat treated plates

(**) Weight for chain with roller "Type C"

Additional features:

- rollers of nylon, delrin, etc
- in STAINLESS steel
- surface treatments of zinc plating, nickel plating, etc.
- pre-tensioned and labelled



METRIC CHAINS, DIN 8165

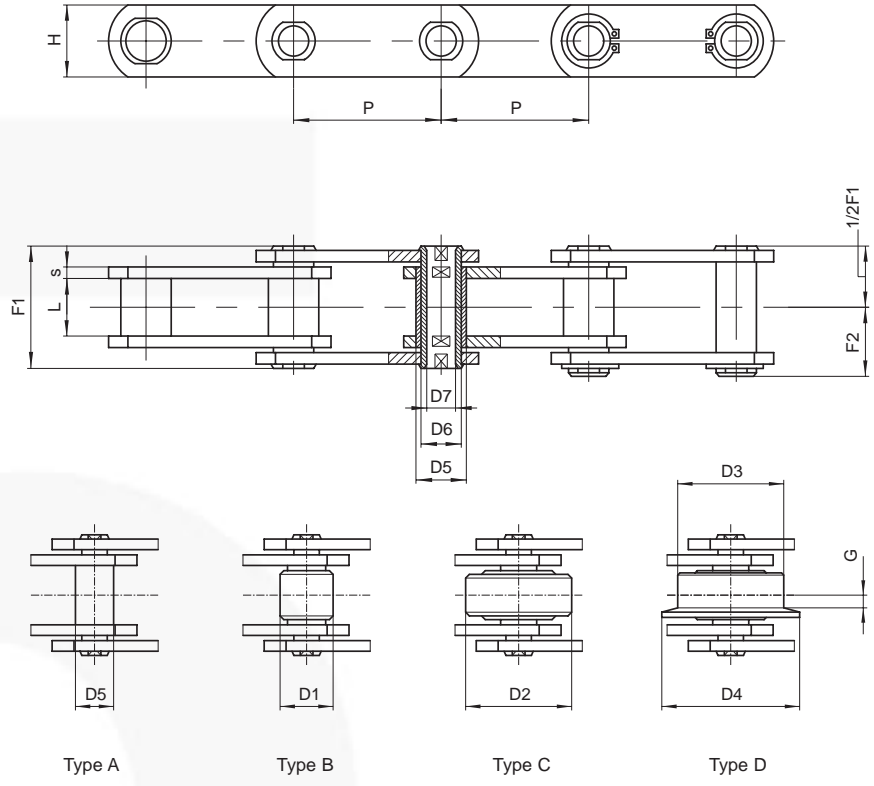

HOLLOW PIN CHAINS

DIN N.	Chain N.	P mm	L mm	D1 mm	D2 mm	D3 mm	D4 mm	G mm	D5 mm	D6 mm	D7 mm	H mm	S mm	F1 mm	F2 mm	Breaking load N	Chain weight kg/m**
FV180	CC 145	125	45	42	70	100	125	13	30	20	14	50	8	86	45	145.000	18,2
"	"	160	"	"	"	"	"	"	"	"	"	"	"	"	"	"	15,6
"	"	200	"	"	"	"	"	"	"	"	"	"	"	"	"	"	13,8
"	"	250	"	"	"	"	"	"	"	"	"	"	"	"	"	"	12,3
"	"	315	"	"	"	"	"	"	"	"	"	"	"	"	"	"	11
FV250	CC 215	160	55	50	80	125	155	15	36	26	18	60	8	97	55	215.000	20,5
"	"	200	"	"	"	"	"	"	"	"	"	"	"	"	"	"	18
"	"	250	"	"	"	"	"	"	"	"	"	"	"	"	"	"	15,9
"	"	315	"	"	"	"	"	"	"	"	"	"	"	"	"	"	14,2
FV315	CC 295	160	65	60	90	140	175	18	42	30	20	70	10	117	63	295.000	34,1
"	"	200	"	"	"	"	"	"	"	"	"	"	"	"	"	"	29,5
"	"	250	"	"	"	"	"	"	"	"	"	"	"	"	"	"	25,8
"	"	315	"	"	"	"	"	"	"	"	"	"	"	"	"	"	22,8
"	"	400	"	"	"	"	"	"	"	"	"	"	"	"	"	"	20,2

(*) Breaking load with heat treated plates

(**) Weight for chain with roller "Type C"

- Additional features:
- rollers of nylon, delrin, etc
 - in STAINLESS steel
 - surface treatments of zinc plating, nickel plating, etc.
 - pre-tensioned and labelled



METRIC CHAINS, DIN 8165

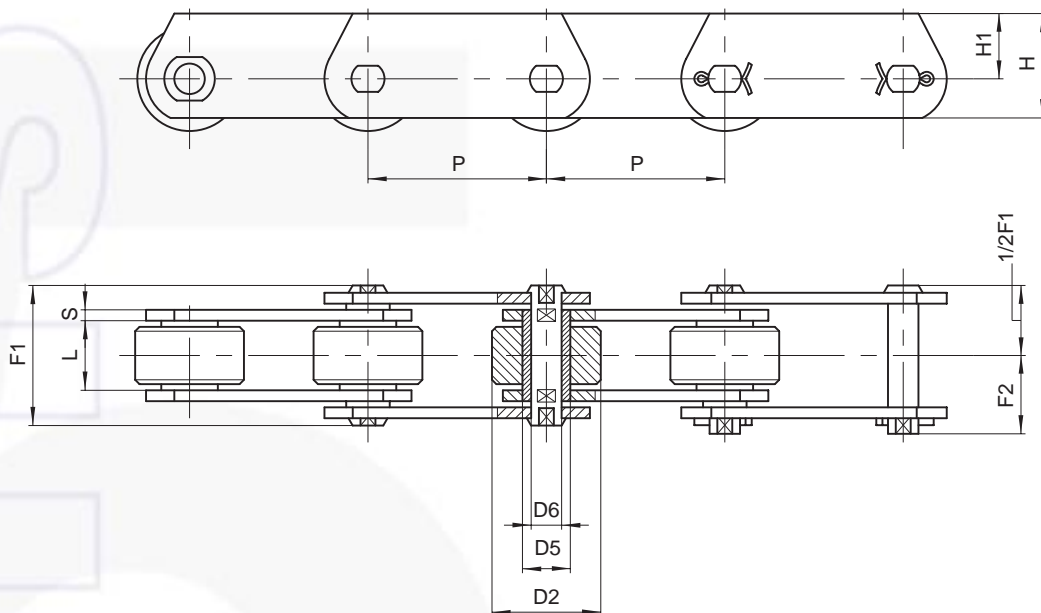

DEEP LINK CHAINS

DIN N.	Chain N.	P mm	L mm	D2 mm	D5 mm	D6 mm	H mm	H1 mm	S mm	F1 mm	F2 mm	Breaking load		Chain weight kg/m
												N	N*	
FVT40	CE 42	50	18	32	15	10	35	22,5	3	36	21	42.000	47.000	5
"	"	63	"	"	"	"	"	"	"	"	"	"	"	4,3
"	"	80	"	"	"	"	"	"	"	"	"	"	"	3,8
"	"	100	"	"	"	"	"	"	"	"	"	"	"	3,4
"	"	125	"	"	"	"	"	"	"	"	"	"	"	3
FVT63	CE 64	63	22	40	18	12	40	25	4	45	26	64.000	75.000	7,5
"	"	80	"	"	"	"	"	"	"	"	"	"	"	6,5
"	"	100	"	"	"	"	"	"	"	"	"	"	"	5,7
"	"	125	"	"	"	"	"	"	"	"	"	"	"	5,1
"	"	160	"	"	"	"	"	"	"	"	"	"	"	4,5
FVT90	CE 100	63	25	48	20	14	45	27,5	5	53	30	100.000	115.000	11,7
"	"	80	"	"	"	"	"	"	"	"	"	"	"	10
"	"	100	"	"	"	"	"	"	"	"	"	"	"	8,7
"	"	125	"	"	"	"	"	"	"	"	"	"	"	7,7
"	"	160	"	"	"	"	"	"	"	"	"	"	"	6,8
"	"	200	"	"	"	"	"	"	"	"	"	"	"	5,8
"	"	250	"	"	"	"	"	"	"	"	"	"	"	5,4
FVT112	CE 120	100	30	55	22	16	50	30	6	62	35	120.000	170.000	12,7
"	"	125	"	"	"	"	"	"	"	"	"	"	"	11,7
"	"	160	"	"	"	"	"	"	"	"	"	"	"	9,7
"	"	200	"	"	"	"	"	"	"	"	"	"	"	8,7
"	"	250	"	"	"	"	"	"	"	"	"	"	"	8

(*) Breaking load with heat treated plates

Additional features:

- rollers of nylon, delrin, etc
- in STAINLESS steel
- surface treatments of zinc plating, nickel plating, etc.
- pre-tensioned and labelled



METRIC CHAINS, DIN 8165

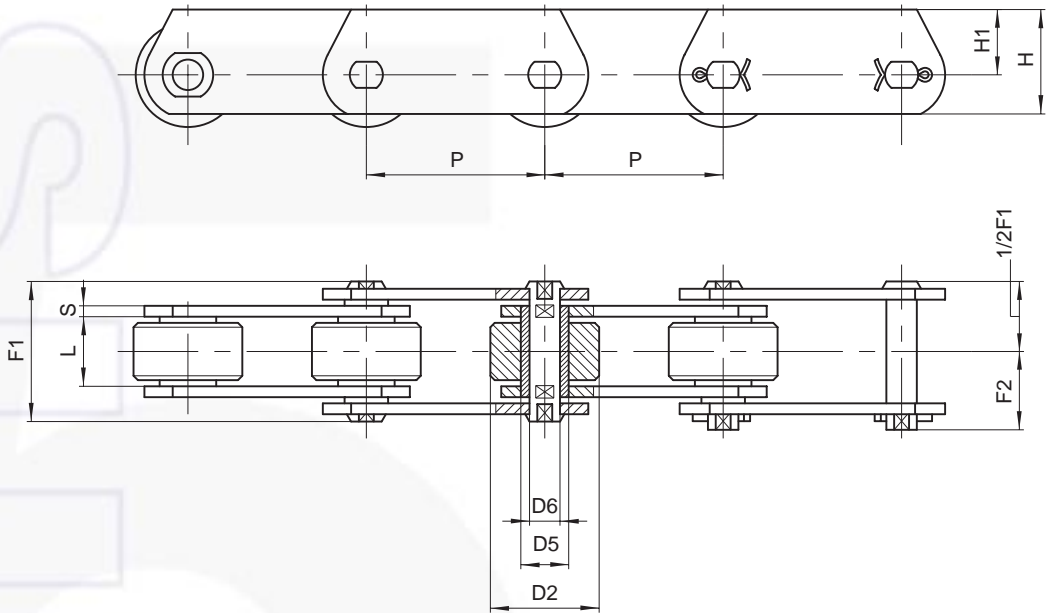

DEEP LINK CHAINS

DIN N.	Chain N.	P mm	L mm	D2 mm	D5 mm	D6 mm	H mm	H1 mm	S mm	F1 mm	F2 mm	Breaking load N*		Chain weight kg/m
FVT140	CE 145	100	35	60	25	18	60	37,5	6	67	38	145.000	180.000	16,8
"	"	125	"	"	"	"	"	"	"	"	"	"	"	14,6
"	"	160	"	"	"	"	"	"	"	"	"	"	"	12,6
"	"	200	"	"	"	"	"	"	"	"	"	"	"	11,3
"	"	250	"	"	"	"	"	"	"	"	"	"	"	10,1
FVT180	CE 190	125	45	70	30	20	70	45	8	86	49	190.000	250.000	24,2
"	"	160	"	"	"	"	"	"	"	"	"	"	"	20,8
"	"	200	"	"	"	"	"	"	"	"	"	"	"	18,4
"	"	250	"	"	"	"	"	"	"	"	"	"	"	16,5
"	"	315	"	"	"	"	"	"	"	"	"	"	"	14,9
FVT250	CE 275	160	55	80	36	26	80	50	8	97	55	275.000	300.000	28,2
"	"	200	"	"	"	"	"	"	"	"	"	"	"	24,5
"	"	250	"	"	"	"	"	"	"	"	"	"	"	21,7
"	"	315	"	"	"	"	"	"	"	"	"	"	"	19,3
FVT315	CE 295	160	65	90	42	30	90	55	10	26		370.000	480.000	39,9
"	"	200	"	"	"	"	"	"	"	"	"	"	"	34,8
"	"	250	"	"	"	"	"	"	"	"	"	"	"	30,6
"	"	315	"	"	"	"	"	"	"	"	"	"	"	27,3
"	"	400	"	"	"	"	"	"	"	"	"	"	"	24,5

(*) Breaking load with heat treated plates

Additional features:

- rollers of nylon, delrin, etc
- in STAINLESS steel
- surface treatments of zinc plating, nickel plating, etc.
- pre-tensioned and labelled





ANSI
Standard
Chain

ANSI STANDARD CHAINS



ANSI STANDARD CHAINS

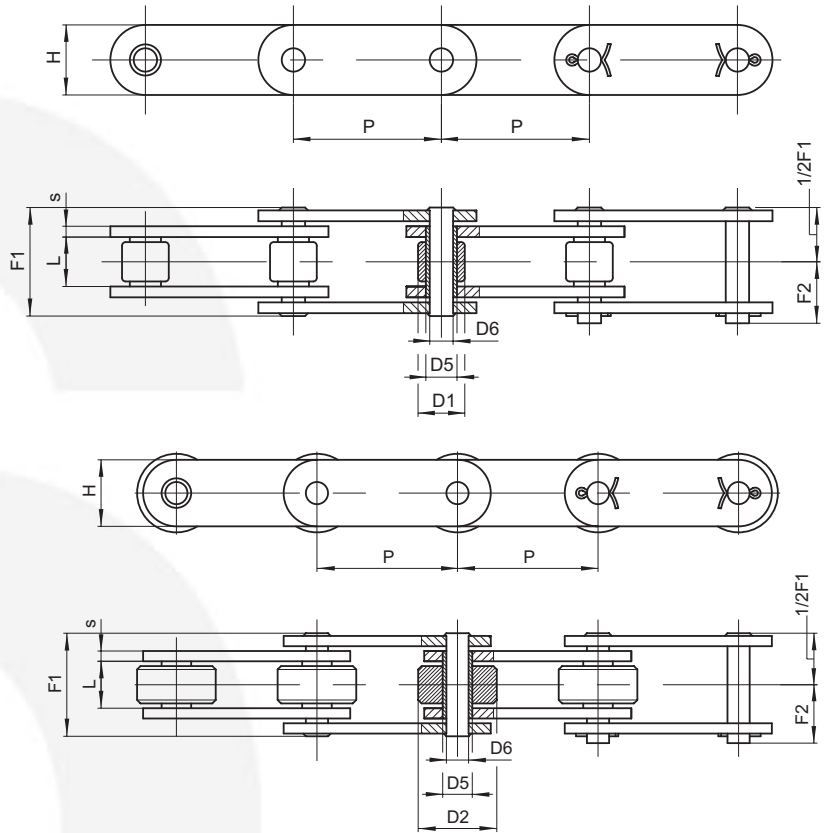

SOLID PIN CHAINS

Chain N.	P mm	L mm	D1 mm	D2 mm	D5 mm	D6 mm	H mm	S mm	F1 mm	F2 mm	Breaking load N	Chain weight kg/m
C2050	31,75	9,53	10,16	/	7	5,08	15,1	2,03	20,5	13,4	26.500	0,80
C2052	31,75	9,53	/	19,05	7	5,08	15,1	2,03	20,5	13,4	26.500	1,3
C2060H	38,10	12,70	11,91	/	8,32	5,93	18	3*	29	17,5	38.000	1,60
C2062H	38,10	12,70	/	22,23	8,32	5,93	18	3*	29	17,5	38.000	2,25
C2080H	50,80	15,88	15,88	/	11	7,92	22,2	4*	36,5	21,3	66.000	2,40
C2082H	50,80	15,88	/	28,58	11	7,92	22,2	4*	36,5	21,3	66.000	3,40
C2100H	63,5	19,05	19,05	/	13,68	9,53	28,5	5*	44	25,5	109.000	3,60
C2102H	63,5	19,05	/	40	13,68	9,53	28,5	5*	44	25,5	109.000	5,80
C2120H	76,20	25,40	22,23	/	17*	12*	35	6*	53,8	30,5	154.000	5,30
C2122H	76,20	25,40	/	44,45	17*	12*	35	6*	53,8	30,5	154.000	8,70

(*) Dimensions not to ANSI standard

Additional features:

- rollers of nylon, delrin, etc.
- with extended pins
- central hole \varnothing 8,15 mm on every pitch both sides, for chain C2060H
- in STAINLESS steel
- surface treatments of zinc plating, nickel plating, etc.
- pre-tensioned and labelled



ANSI STANDARD CHAINS

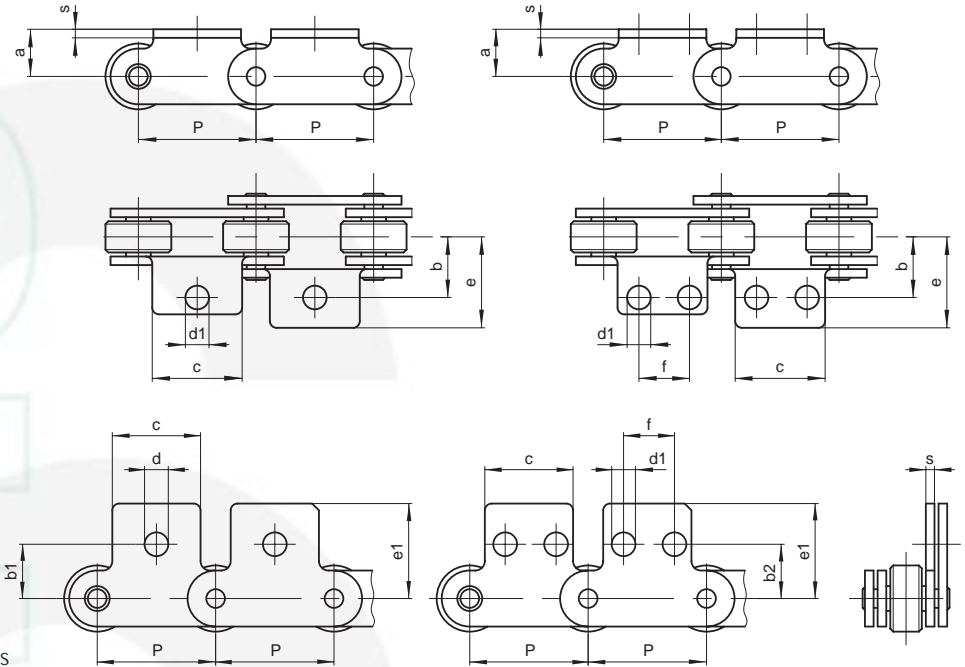

Layout of attachments
on page 1.9/2

ATTACHMENTS

Chain N.	P mm	a mm	b mm	b1 mm	b2 mm	c mm	d mm	d1 mm	e mm	e1 mm	f mm	s mm	Weight per attach. kg
C2050	31,75	11,1	15,9	14,2	15,9	25,4	6,4	5,2	24,7	24,2	11,9	2,03	0,008
C2052	31,75	11,1	15,9	14,2	15,9	25,4	6,4	5,2	24,7	24,2	11,9	2,03	0,008
C2060H	38,10	14,7	21,4	19,05*	17,5*	28	8,8	5,6	31	30	14,3	3	0,012
C2062H	38,10	14,7	21,4	19,05*	17,5*	28	8,8	5,6	31	30	14,3	3	0,012
C2080H	50,80	19,05	27,8	22,2*	25,4*	38	11	6,8	39,3	38	19	4	0,029
C2082H	50,80	19,05	27,8	22,2*	25,4*	38	11	6,8	39,3	38	19	4	0,029
C2100H	63,5	23,4	33,1	28,6	31,8	47,5	13,1	8,8	49,2	48,2	23,8	4,8	0,067
C2102H	63,5	23,4	33,1	28,6	31,8	47,5	13,1	8,8	49,2	48,2	23,8	4,8	0,067
C2120H	76,20	27,8	39,7	33,3	37,3	57	15	11	59,2	57	28,6	5,65	0,105
C2122H	76,20	27,8	39,7	33,3	37,3	57	15	11	59,2	57	28,6	5,65	0,105

(*) Dimensions not to ANSI standard





chains
7

CHAINS FOR SPECIAL APPLICATIONS



CHAINS FOR SPECIAL APPLICATIONS – FOOD INDUSTRY

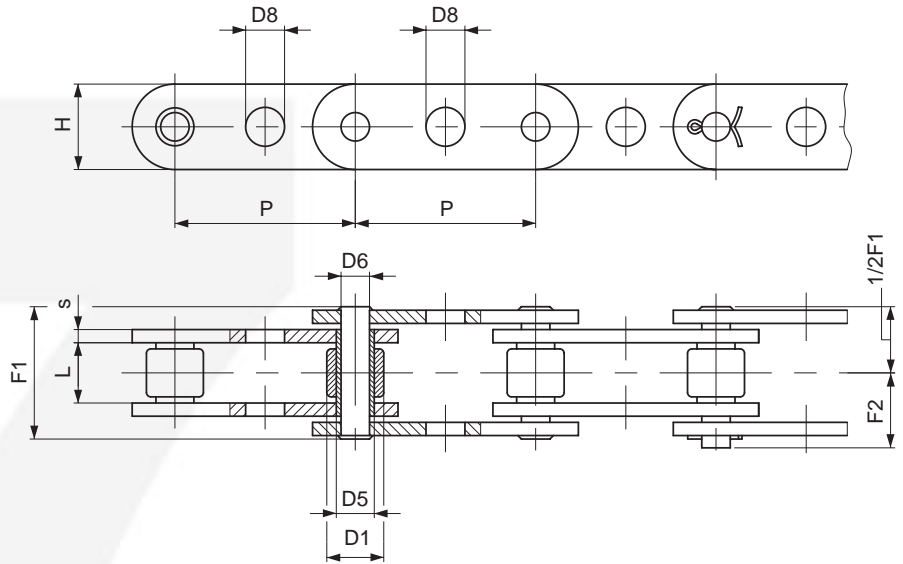

ELECTRONIC GRADING MACHINE

Chain N.	P mm	L mm	D1 mm	D5 mm	D6 mm	D8 mm	H mm	S mm	F1 mm	F2 mm	Breaking load N	Chain weight kg/m
❖ C2060HFFPT	38,1	12,7	11,91	8,4	6	8,2	18	3	29,2	18	38.000	1,6
❖ W3609...	44,45	12,7	11,91	8,4	6	8,1	18	3	29,2	18	38.000	1,4
❖ W4376...	50	11,7	12,07	8,3	6	8,1	17	2,5	27	16	20.000	1,2

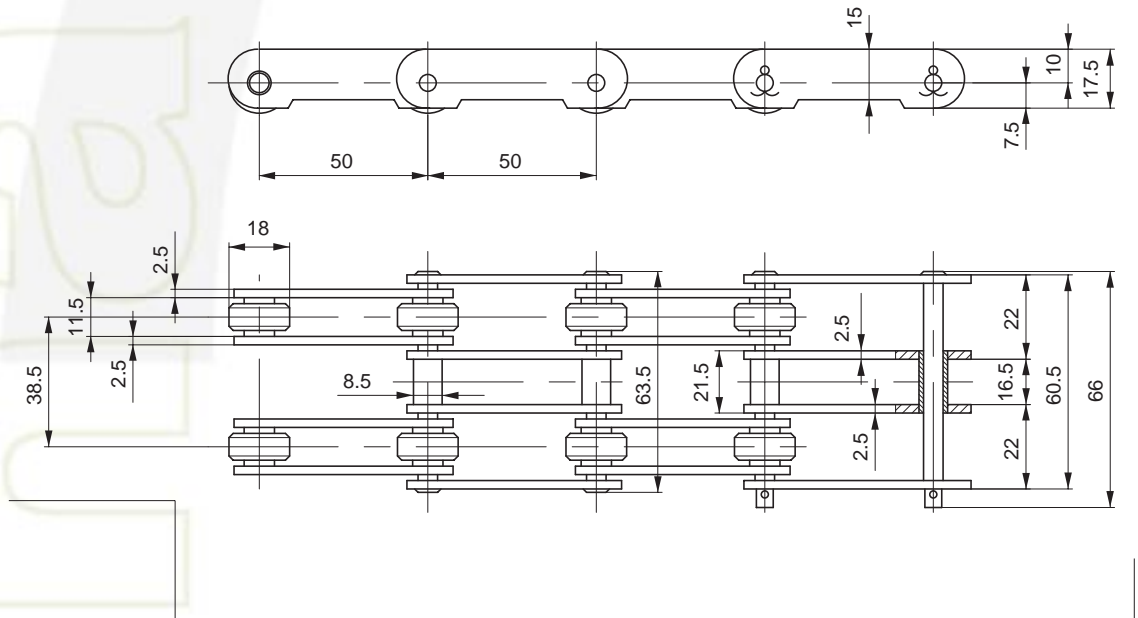

TRIPLE chain P. 50x11,5x18øR ZINC PLATED

Breaking load: 32.000 N

❖ zinc plated execution



CHAINS FOR SPECIAL APPLICATIONS – FOOD INDUSTRY

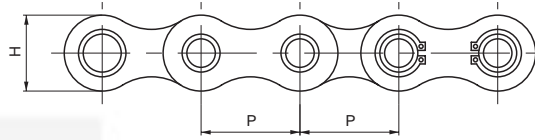

Layout of attachments
on page 1.9/2

HOLLOW PIN CHAINS

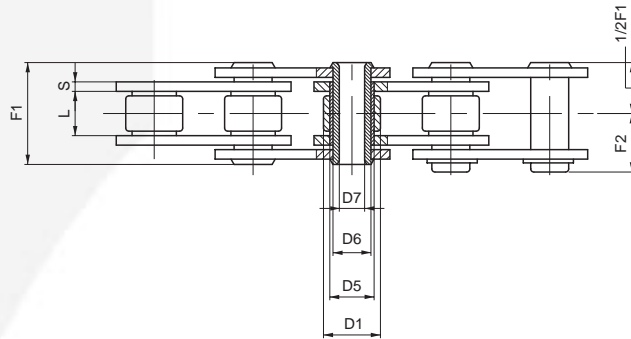

Chain N.	P mm	L mm	D1 mm	D5 mm	D6 mm	D7 mm	H mm	S mm	F1 mm	F2 mm	Breaking load N	Chain weight kg/m
❖ 3520Z	35	16	20	17	14	10,4	26	2,5	31	16,7	25.000	2,2
3520R	35	16	20	17	14	10,4	26	2,5	31	16,7	40.000	2,2
❖ 4020Z	40	16	20	17	14	10,4	30	2,5	31	16,7	25.000	2,3

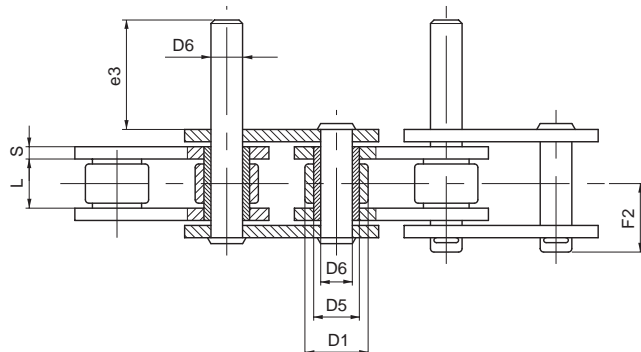
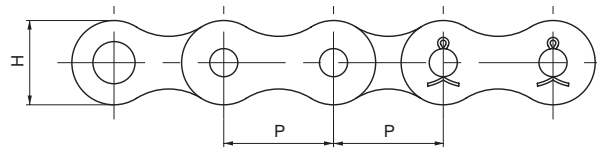

WITH EXTENDED PINS

Chain N.	P mm	L mm	D1 mm	D5 mm	D6 mm	H mm	S mm	F2 mm	F6 mm	e3 mm	Breaking load N	Chain weight kg/m
❖ 3521Z	35	16	20	13	10	26	2,5	50,5	67,5	35	35.000	2,8
▲ W3033...	38,1	13	12	8,5	10	18	3	17,5	80,0	35	38.000	2,2
▲ W3109...	38,1	13	22,5	8,5	10	18	3	17,5	80,0	35	38.000	2,3

❖ zinc plated execution

▲ zinc plated or nickel plated execution



CHAINS FOR SPECIAL APPLICATIONS – AUTOMOTIVE INDUSTRY

PENDULUM
CHAINS

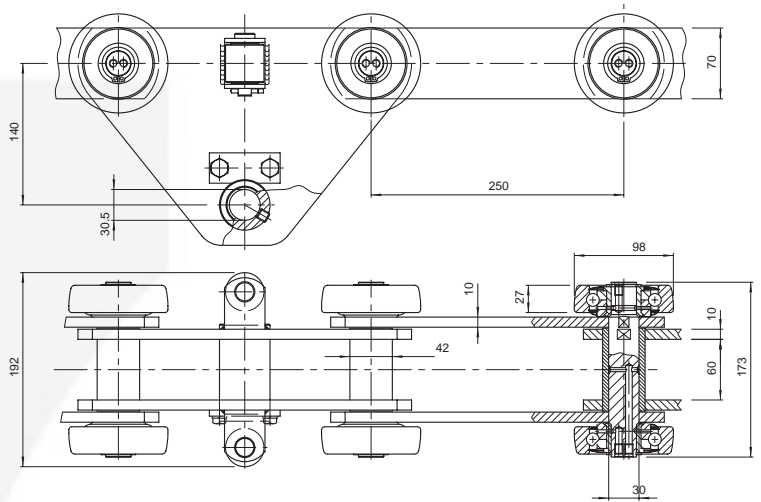

Chain P. 250x60x42 øB

 Breaking load: 370.000 N

PENDULUM
CHAINS

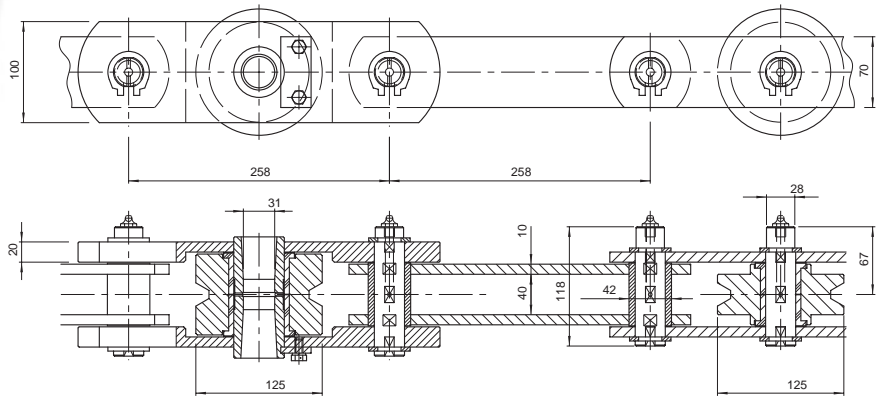

Chain P. 258x40x42 øB

 Breaking load: 405.000 N



CHAINS FOR SPECIAL APPLICATIONS – AUTOMOTIVE INDUSTRY

PENDULUM
CHAINS

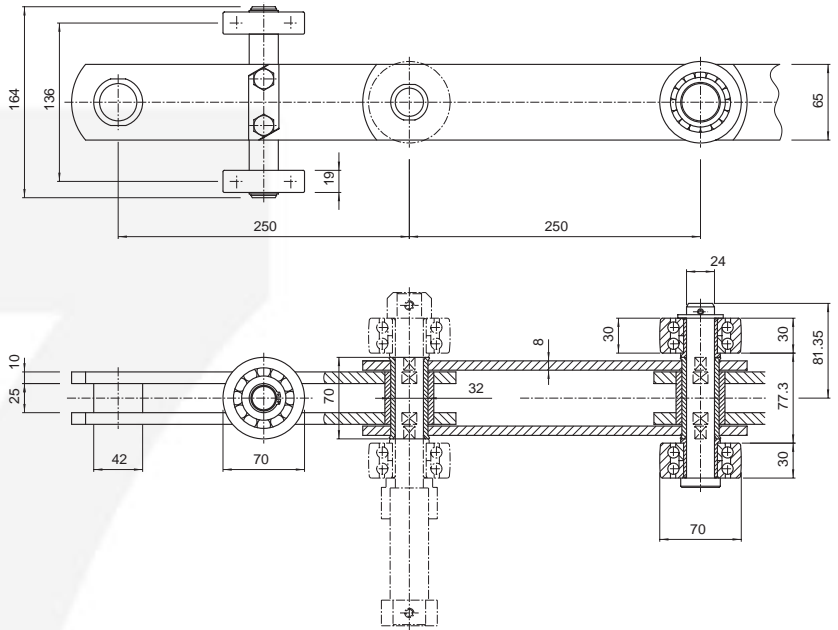

Chain P. 250x25x42 øB

 Breaking load: 380.000 N

PENDULUM
CHAINS

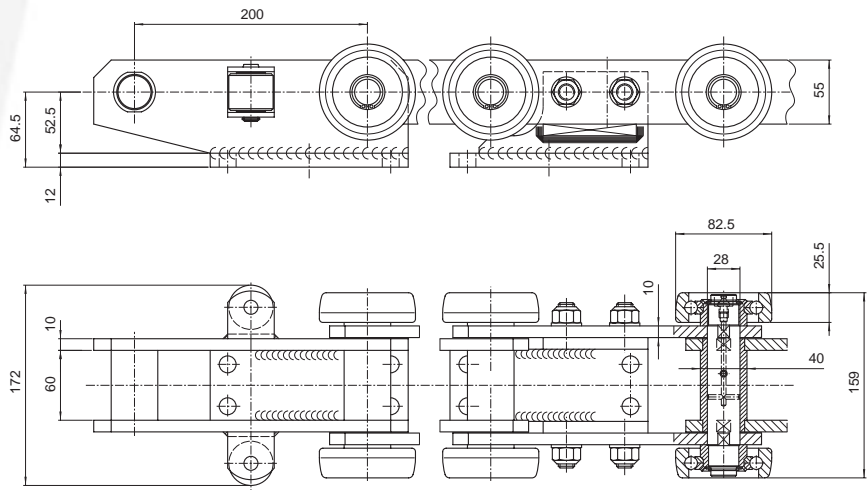

Chain P. 200x60x40 øB

 Breaking load: 300.000 N



CHAINS FOR SPECIAL APPLICATIONS – AUTOMOTIVE INDUSTRY

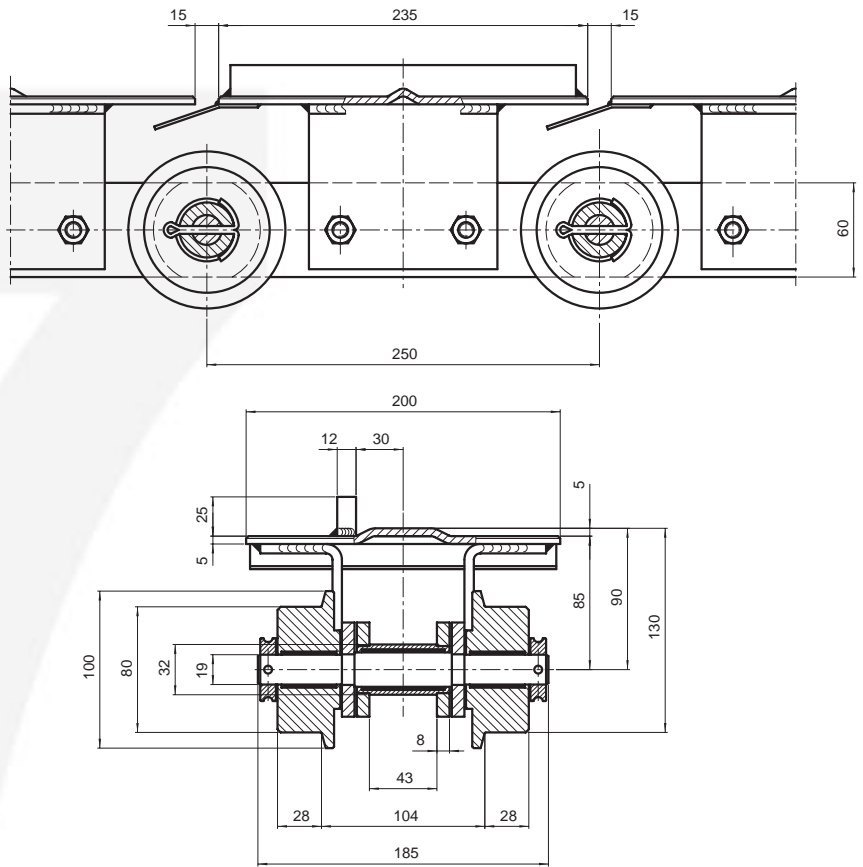

DRYING
OVENS

Chain P. 250x43x32 øB



Breaking load: 224.000 N

Lubrication and maintenance free
through MECASEC®
(registered trade mark by P.T.F.E. Sarl)



CHAINS FOR SPECIAL APPLICATIONS – AUTOMOTIVE INDUSTRY

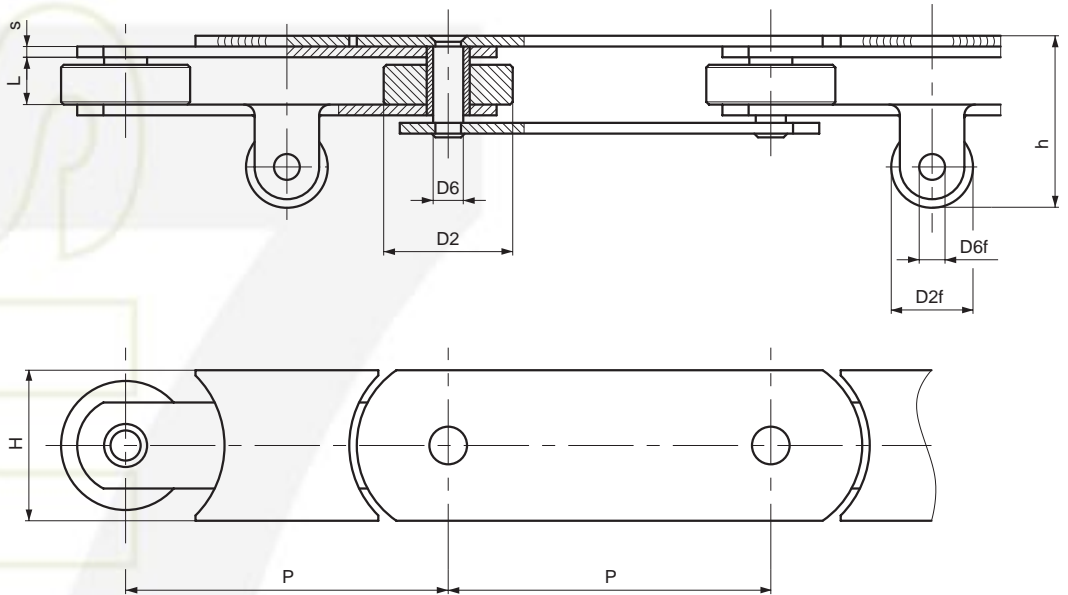

SKID CONVEYORS

Chain N.	P mm	L mm	D2 mm	D6 mm	H mm	S mm	D2f mm	D6f mm	h mm	Breaking load N
W4697	100	22	60	14	70	5	38	12	81	160.000
W2527R	150	22	60	14	70	5	38	12	81	160.000
W2542R	150	22	60	22	80	8	70	18	131	220.000
W4028R	150	22	60	14	100	5	38	12	81	160.000
W2595R	150	22	60	14	80	5	38	12	81	160.000

CHAINS FOR SPECIAL APPLICATIONS – AUTOMOTIVE INDUSTRY

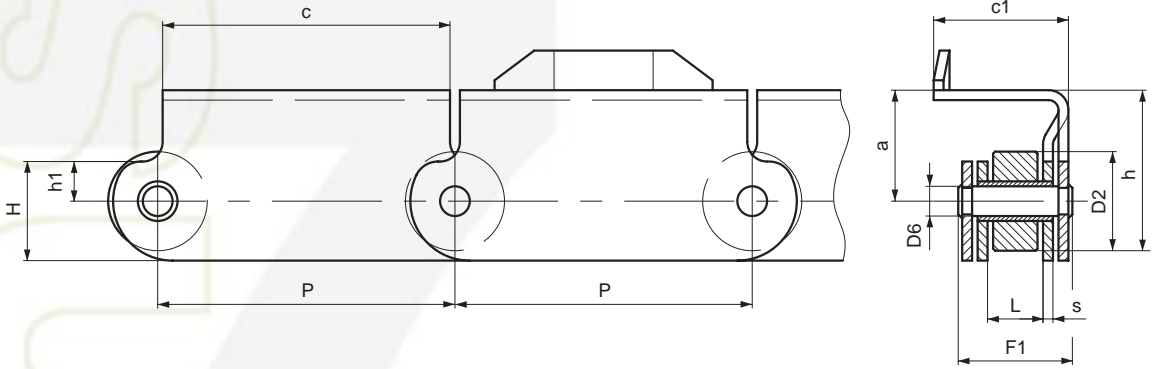

SKID CONVEYORS

Chain N.	P mm	L mm	D2 mm	D6 mm	H mm	h mm	h1 mm	S mm	F1 mm	a mm	c mm	c1 mm	Breaking load N
W2359	150	28	50	15	50	81	20	5	55	56	145	68	160.000
W3057	150	28	50	15	50	85	20	5	55	60	145	65	160.000
W3349	150	32	50	14	55	81	20	5	58,5	56	145	80	160.000
W2387	150	32	50	14	55	81	20	6	63	56	145	80	160.000



CHAINS FOR SPECIAL APPLICATIONS – AUTOMOTIVE INDUSTRY

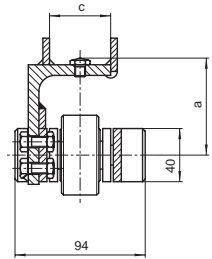
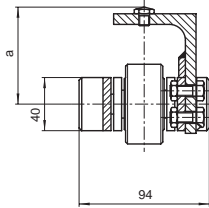
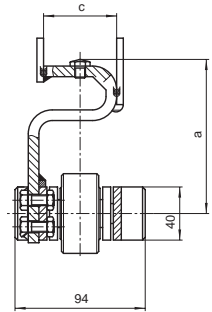
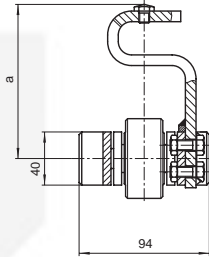
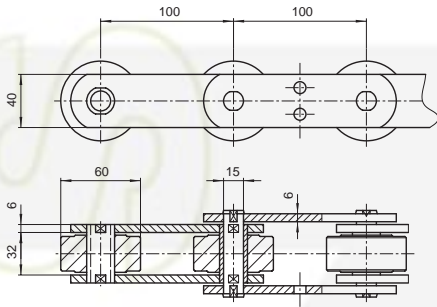

SKID
CONVEYORS

Chain P. 100x32x60 øR



Breaking load: 112.000 N

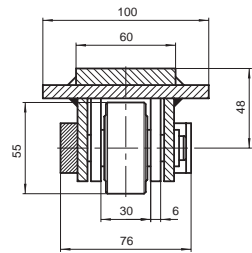
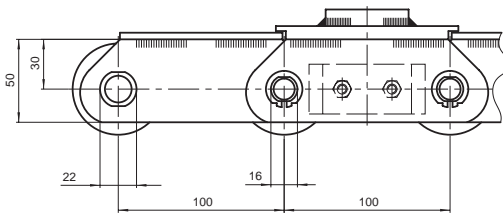
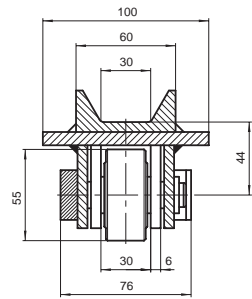
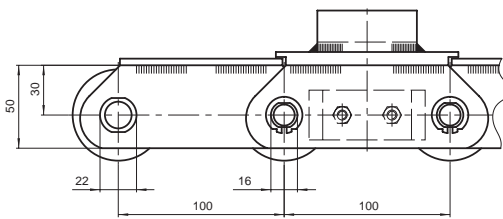

SKID
CONVEYORS

Chain P. 100x30x55 øR



Breaking load: 120.000 N



CHAINS FOR SPECIAL APPLICATIONS – AUTOMOTIVE INDUSTRY

SKID
CONVEYORS

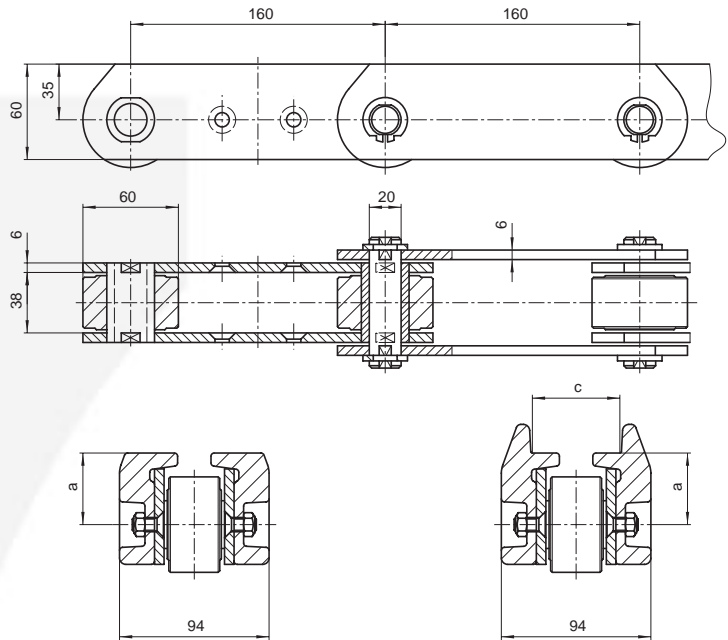

Chain P. 160x38x60 øR

 Breaking load: 200.000 N

SKID
CONVEYORS

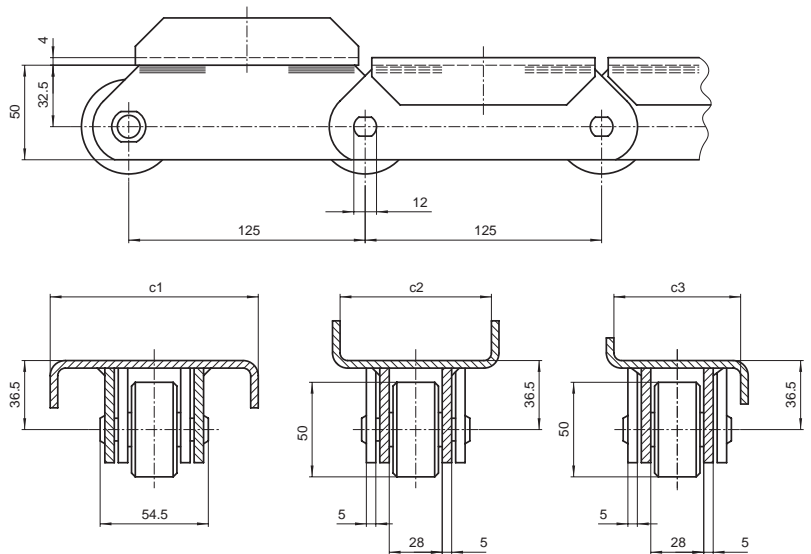

Chain P. 125x28x50 øR

 Breaking load: 80.000 N



CHAINS FOR SPECIAL APPLICATIONS – AUTOMOTIVE INDUSTRY

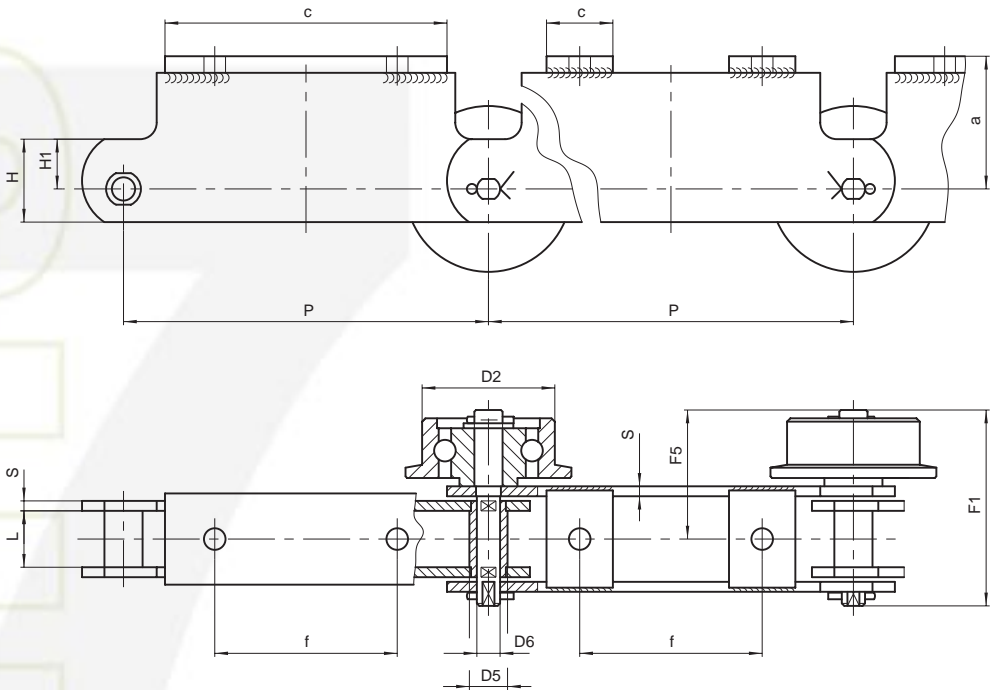

CAR
CONVEYING

Chain N.	P mm	L mm	D2 mm	D5 mm	D6 mm	H mm	H1 mm	S mm	F1 mm	F5 mm	a mm	c mm	f mm	Breaking load N
W3810	220	34	80	23	14	50	31	6	114,5	76	80	170	110	140.000
W4031L	220	34	80	30	20	90	60	6	115	76	72	40	154	224.000
W4986LR	220	34	80	30	20	60	25	6	130,5	91,5	65	50	170	224.000
W4779	250	32	80	21	15	60	40	6	110,5	73,5	48	50	140	112.000
W4952	250	32	100	34	25	100	60	6	122,5	81,5	70	50	130	240.000
W4999	250	34	/	30	20	80	48	6	116	77	58	50	185	260.000
W5022	250	34	80	30	20	90	60	6	115	76	72	40	184	170.000



CHAINS FOR SPECIAL APPLICATIONS – AUTOMOTIVE INDUSTRY

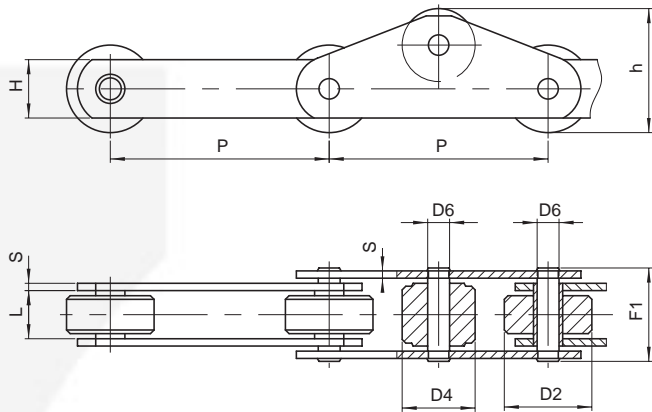

SKIDS
CONVEYORS

Chain N.	P mm	L mm	D2 mm	D4 mm	D6 mm	H mm	S mm	F1 mm	h mm	Breaking load N	Notes
W2165	50	25	20	24	10	25	4	45	32	56.000	RP every outer link
W2165A	50	25	20	24	10	/	4	45	32	56.000	RP every link
W3836A	125	28	25	42	12	35	5	54,5	53,5	80.000	RP every outer link
W1669	150	28	60	50	15	40	5	54,5	85	160.000	RP every outer link
W5165	200	50	60	60	18	50	7	85	65	160.000	RP every link

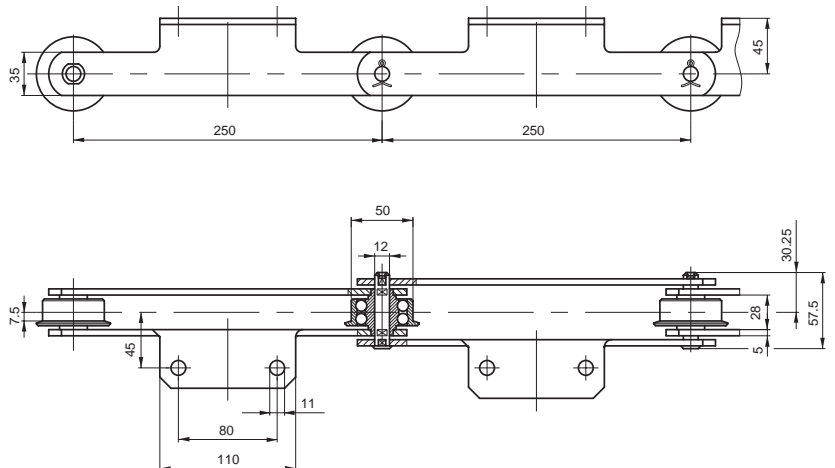

WATER TEST

Chain P. 250x28x50/60 øR

Material:
STAINLESS steel

Sealed roller bearing

Breaking load: 80.000 N



CHAINS FOR SPECIAL APPLICATIONS – AUTOMOTIVE INDUSTRY

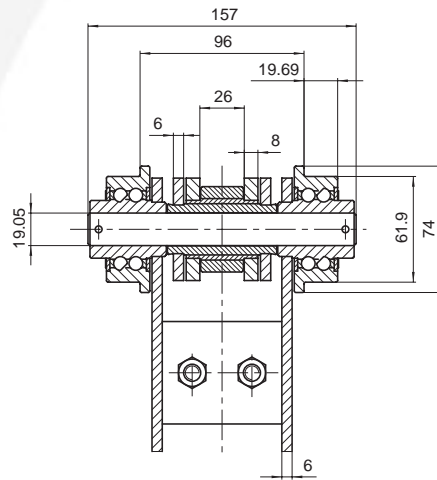
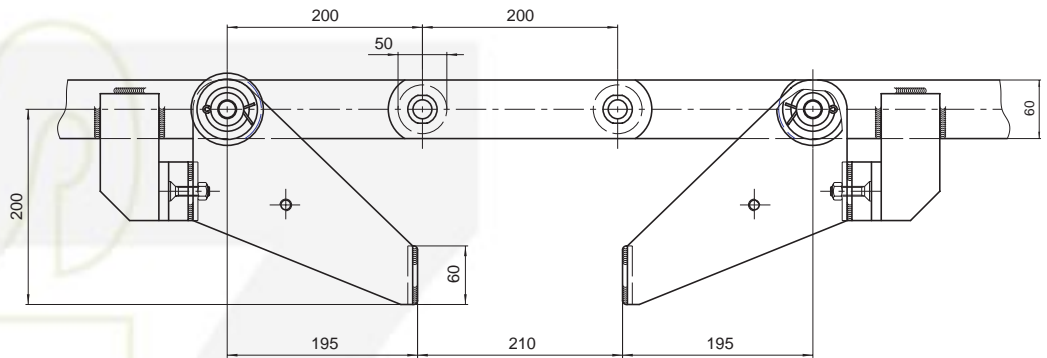

CROSS
TRANSFER
UNITS

Chain P. 200x26x60 øR



Breaking load: 300.000 N



CHAINS FOR SPECIAL APPLICATIONS – AUTOMOTIVE INDUSTRY

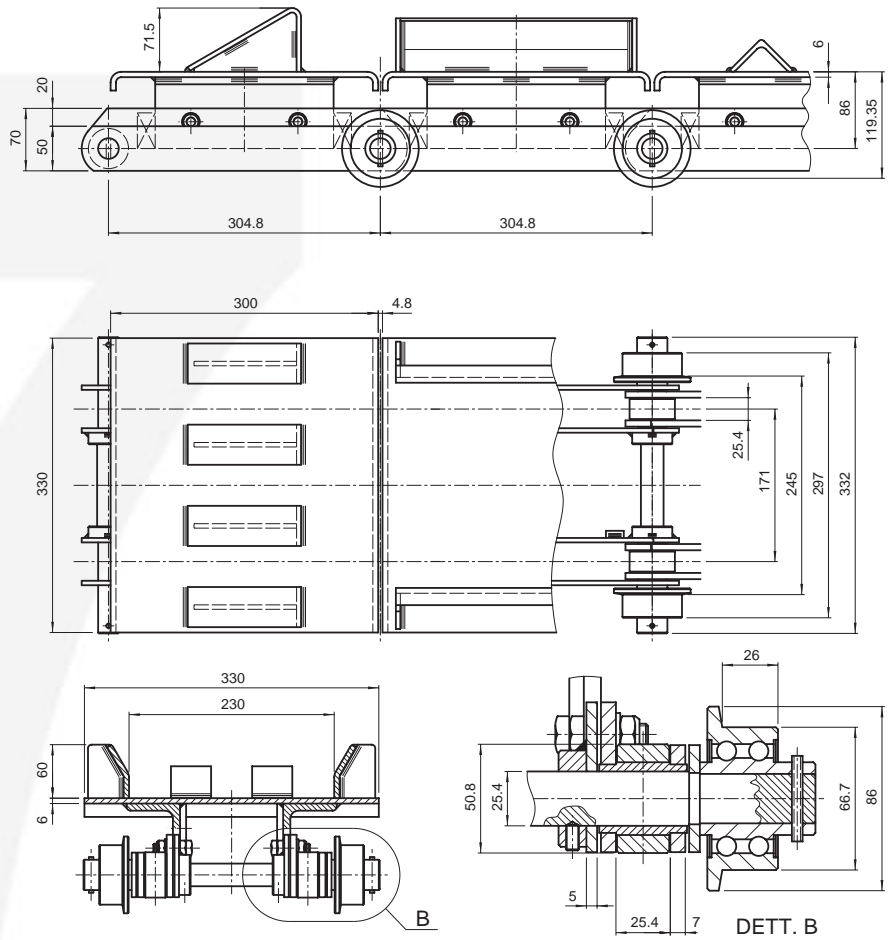

WATER TEST

Chain P. 304,8x25,4x50,8 ØR

Material: treated and zinc plated steels



Breaking load: 300.000 N



CHAINS FOR SPECIAL APPLICATIONS – SHOE INDUSTRY

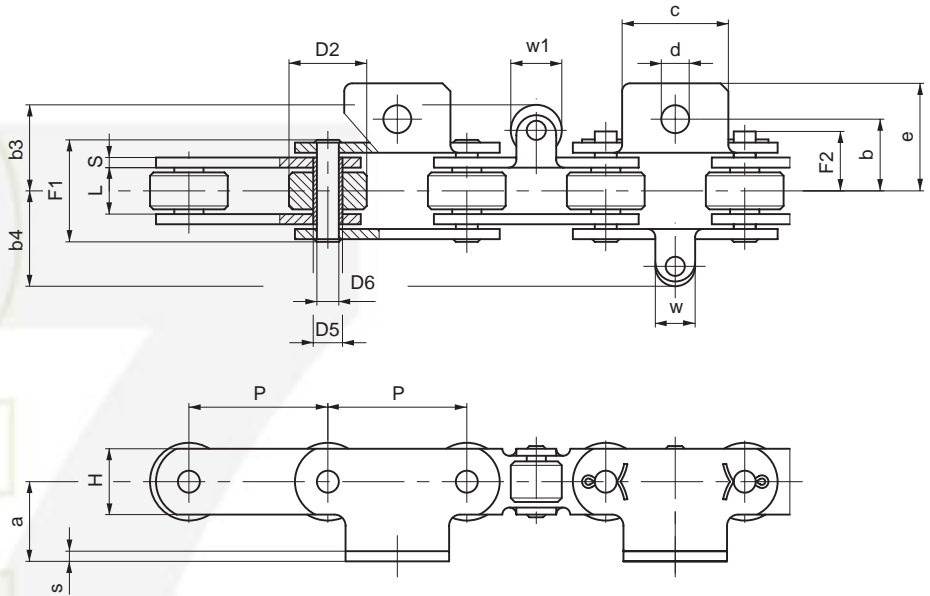

Chain N.	P mm	L mm	D2 mm	D5 mm	D6 mm	H mm	S/s mm	F1 mm	F2 mm	Breaking load N	Chain weight kg/m
10337	50	11,5	25	8,4	5,7	15	2	23,8	14,6	16.000	1,4
10381	50	11,5	25	8,4	5,7	15	2	23,8	14,6	16.000	1,4
103391	50	11,5	25	8,4	5,7	15	2	23,8	14,6	16.000	1,5
103476	50	11,5	25	8,4	5,7	15	2	23,8	14,6	16.000	1,4
W1364A	50	11,5	25	8,4	5,7	14	2,5	24,9	15,7	18.000	1,7
W2518	50	11,5	25	8,4	5,7	15	2	23,8	14,6	16.000	1,4

ATTACHMENTS

Chain N.	P mm	a mm	b mm	c mm	d mm	e mm	w mm	w1 mm	b3 mm	b4 mm	Notes
10337	50	25	21	41	6,5	32	12	/	/	24	
10381	50	24	/	24,5	/	31,2	12	/	/	24	
103391	50	25	21	41	6,5	32	12	14	22,5	24	
103476	50	25	21	41	6,5	32	/	14	22,5	/	
W1364A	50	/	/	41,5	6,5	23,3	/	14	28,8	/	Vertical attachment
W2518	50	24,5	/	40	/	57,5	/	14	22,5	/	



CHAINS FOR SPECIAL APPLICATIONS – PAPER INDUSTRY

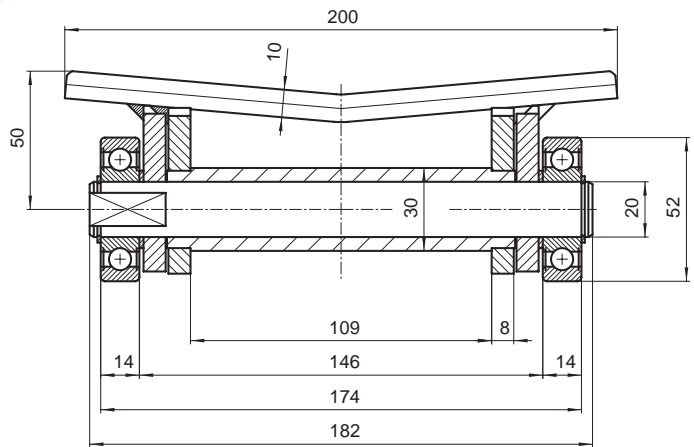
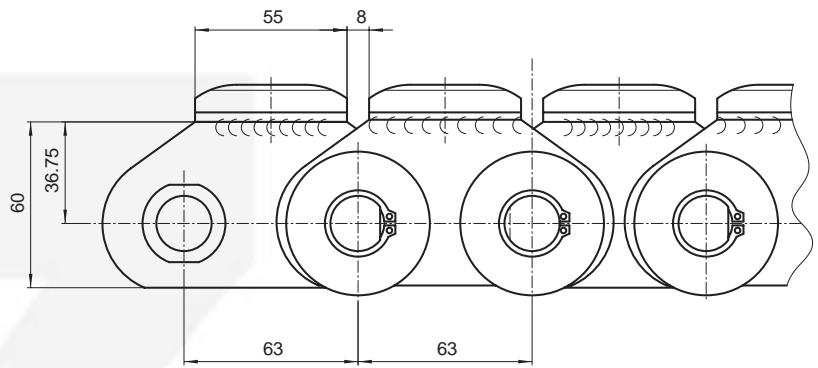

ROLL HANDLING SYSTEM

Chain P. 63x109x30 øB

 Breaking load: 210.000 N

Outboard ball bearings, both sides



CHAINS FOR SPECIAL APPLICATIONS – PAPER INDUSTRY

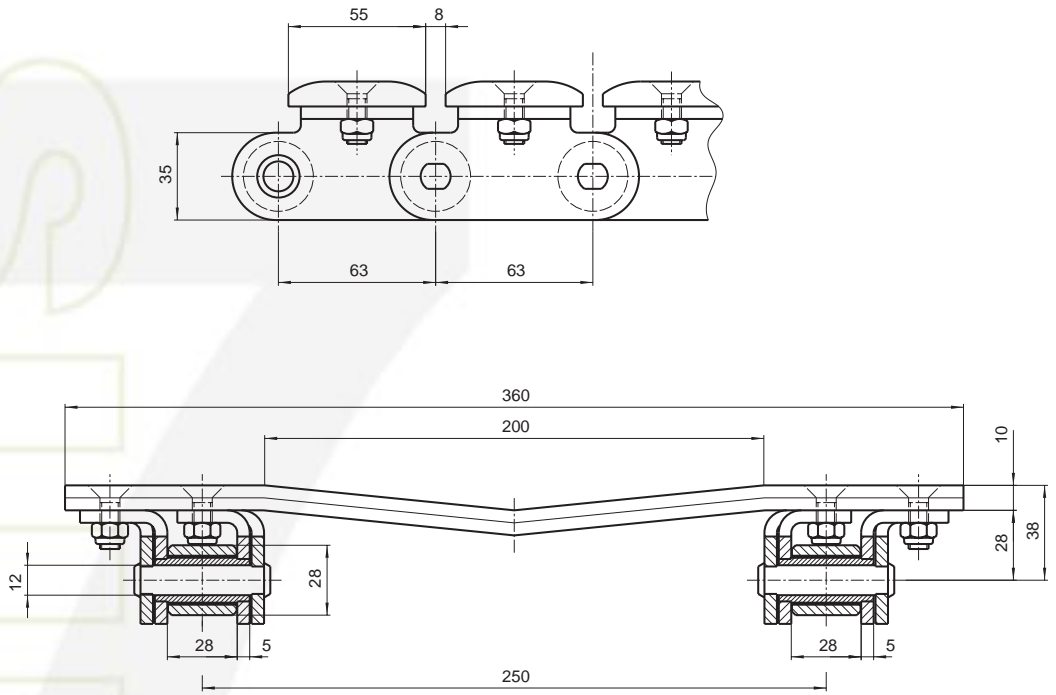

ROLL HANDLING SYSTEM

Chain P. 63x28x28 øR



Breaking load: 80.000 N (each chain)



CHAINS FOR SPECIAL APPLICATIONS – PAPER INDUSTRY

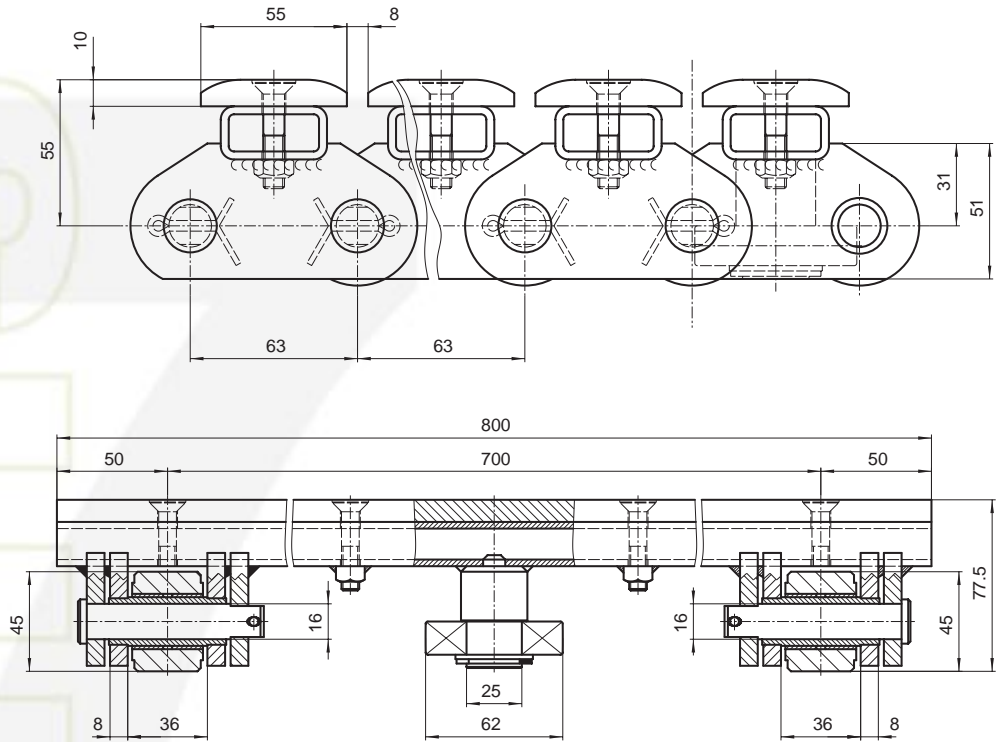

ROLL HANDLING SYSTEM

Chain P. 63x36x45 øR



Breaking load: 120.000 N (each chain)



CHAINS FOR SPECIAL APPLICATIONS – PROVER INDUSTRY

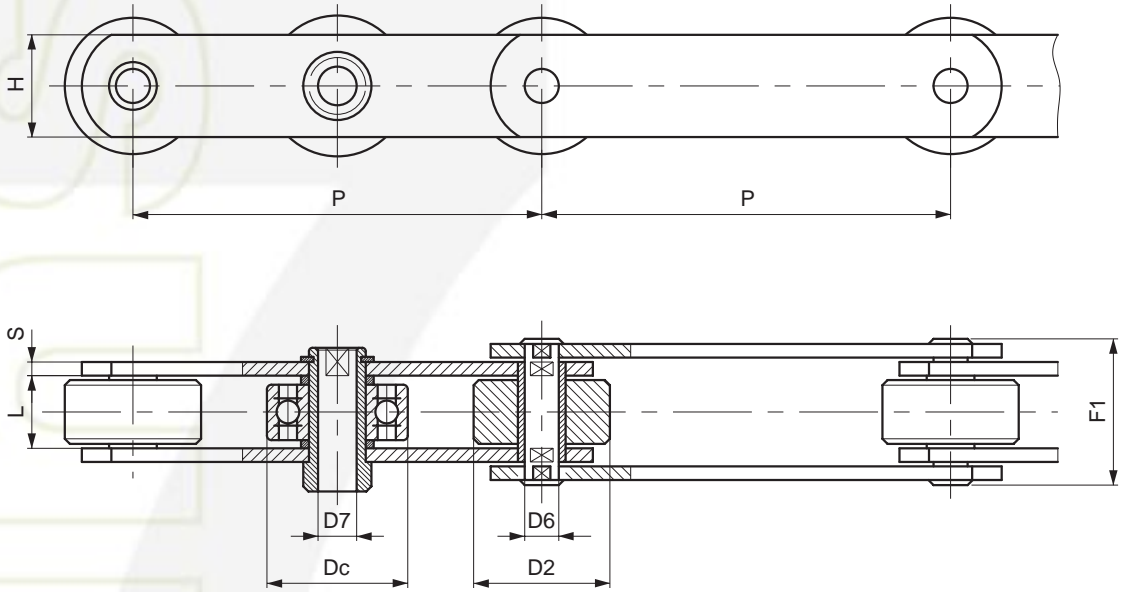

SWINGING TRAYS CONVEYORS

Chain N.	P mm	L mm	D2 mm	D6 mm	D7 mm	Dc mm	H mm	S mm	F1 mm	 Breaking load N	Notes
W3248	80	28	52	18	12	52	35/40	5	55	80.000	Ball bearing roller
W3513	80	28	52	18	12	52	35/40	5	55	80.000	Ball bearing roller
W4976	140	32	30	21	15	47	40	6	63	170.000	
W4949	152,4	26	60	33	27	62	50	7/5	58	200.000	
W3729	160	32	60	21	15	62	40/45	6	63	140.000	
W4751	160	35	36	25	17	62	45	6	65	180.000	
W3247	180	32	60	21	15	62	40/45	6	63	112.000	
W2498	180	36	70	30	20	72	60	8	77	300.000	
W3064	180	43	70	30	21	72	60	8	84	300.000	
W4937	200	26	60	33	27	62	50	7/5	58	200.000	
W2340	200	36	70	30	20	72	60	8	77	300.000	



CHAINS FOR SPECIAL APPLICATIONS – CANNING INDUSTRY

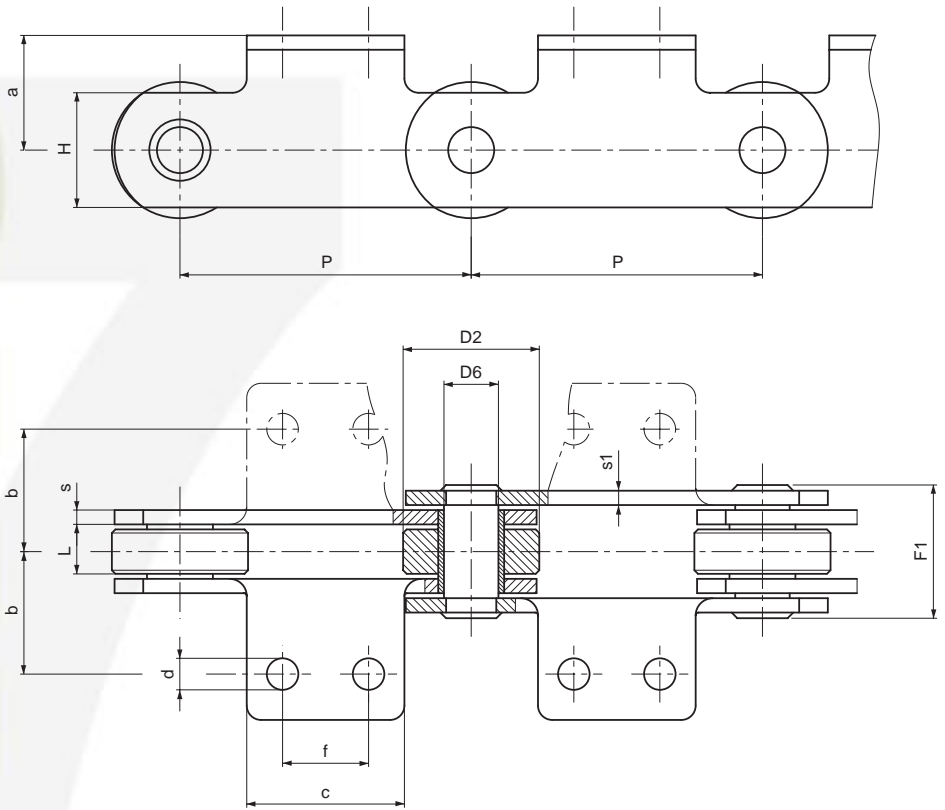

SOLID PIN CHAINS

Chain N.	P mm	L mm	D2 mm	D6 mm	H mm	S/S1 mm	a mm	b mm	c mm	F1 mm	Breaking load N
W2689	50	15	31	10	25	4/4	17,5	34	60	36	65.000
500BRA102	50	15	31	10	25	4/4	17,5	34	60	36	65.000
W4216	76,2	15	31,75	14	26,5	4/4	19	38,1	43	37	34.000
W1829	86	14,5	45	14	35	4/4	7,5	37	35	36,5	74.000
W1826	100	15	45	10	25	4/4	15	47,5	70	36	45.000
W4338	100	22	45	12	35	4/4	33,5	40	70	43	100.000
W3776	101,6	19	47,5	19	40	5/4	38	44,5	63,5	44,8	100.000
W3952	101,6	19	47,5	19	40	5/4	30	44,5	63,5	44,8	100.000
W2554/5	101,6	19	47,5	19	40	5/4	40	41	63,5	44,8	100.000



CHAINS FOR SPECIAL APPLICATIONS – CANNING INDUSTRY

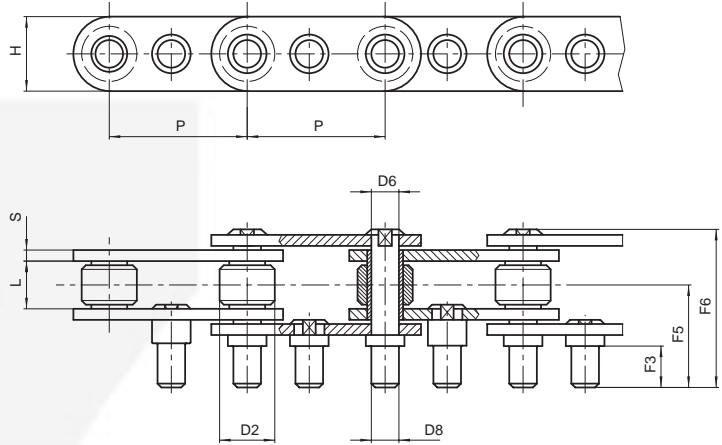

PEEL SEPARATORS

Chain N.	P mm	L mm	D2 mm	D6 mm	D8 mm	H mm	S mm	F3 mm	F5 mm	F6 mm	Breaking load N
W1173	50	15	20	9,85	10	27	4	15	32,5	53,5	75.000
W2938	50	15	20	9,85	10	25	4	15	32,5	57	70.000
W1440	53	16	27	8	8	20	3	17	32,5	53,5	24.000
W1527	53	16	25	8	8	20	3	15	32,5	53,5	50.000

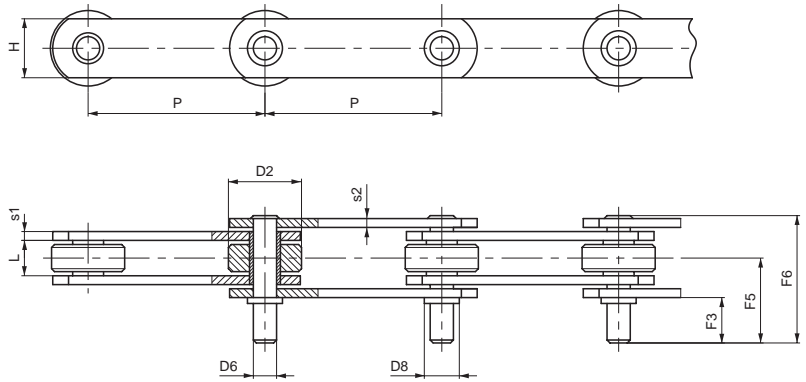

WITH EXTENDED PINS

Chain N.	P mm	L mm	D2 mm	D6 mm	D8 mm	H mm	S1/S2 mm	F3 mm	F5 mm	F6 mm	Breaking load N
500D202	50	15	31	12	16	25	4/4	32	48	66	45.000
W1201	75	15	31	9,85	9,85	25	4/4	20	36	54	75.000
W1200	80	15	31	9,85	9,85	25	4/4	20	36	54	75.000
W2026	88,9	15	31,75	9,85	9,85	25	4/4	20	36	53,5	45.000
W1746	88,9	19	47,5	19,1	/	40	5/4	25	44,2	65,5	100.000
W2832	100	15	32	9,85	15	25	4/4	20	36	53,5	45.000
W1137	101,6	15	38	12	16	25	4/4	25	53,5	72	40.000



CHAINS FOR SPECIAL APPLICATIONS – CANNING INDUSTRY

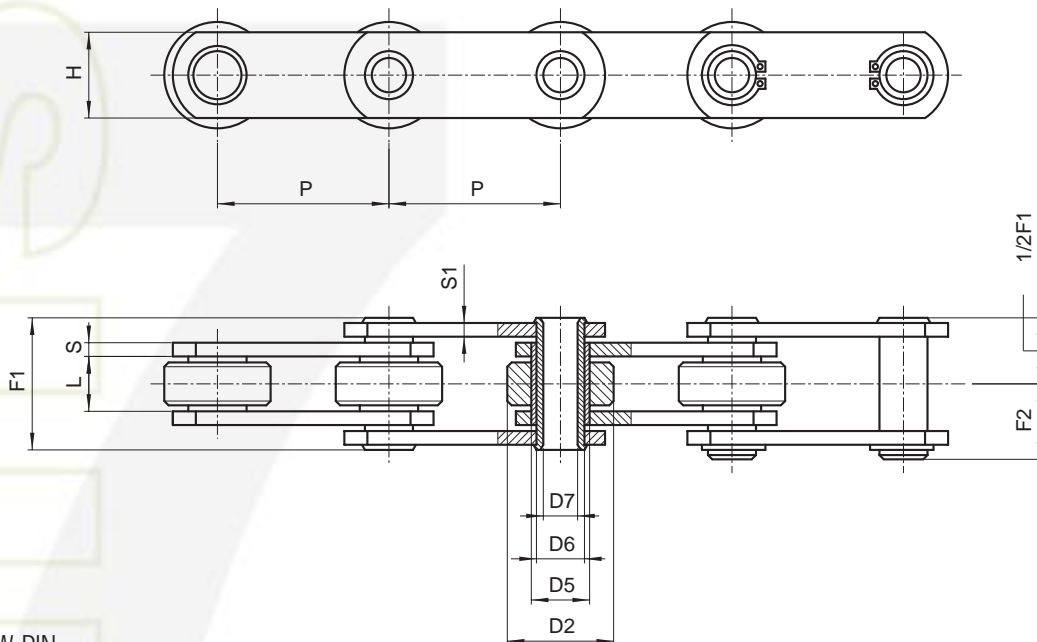

HOLLOW PIN CHAINS

Chain N.	P mm	L mm	D2 mm	D5 mm	D6 mm	D7 mm	H mm	S/S1 mm	F1 mm	Breaking load N
W2003	50	11,5	25	11	9	6,2	20	2,5/2,5	25	25.000
W4886RZV**	76,2	19	47,5	23	19	13,5	40	5/4	44,75	108.000
W1830	86	14,5	45	25	20	14,4	35	4/3	34	50.000
W2058	86	15	45	25	20	14,4	35	5/4	38,5	60.000
W3149	101,6	19	47,5	23,5	19	13,25	40	5/4	43,5	125.000
W2009	101,6	31	47,5	23	18	13,5	40	5/4	43	60.000
W4890RZV**	101,6	19	47,5	23	19	13,5	40	5/4	44,75	108.000
W4894RZV**	127	19	47,5	23	19	13,5	40	5/4	44,75	108.000
W4769	127	19	47,5	23	19	13,5	40	5/4	44,75	69.000
W4962SS*	127	19	47,5	23	19	13,5	40	5/4	44,75	60.000

* STAINLESS steel chain

** green zinc plated execution



CHAINS FOR SPECIAL APPLICATIONS – FOOD OVENS

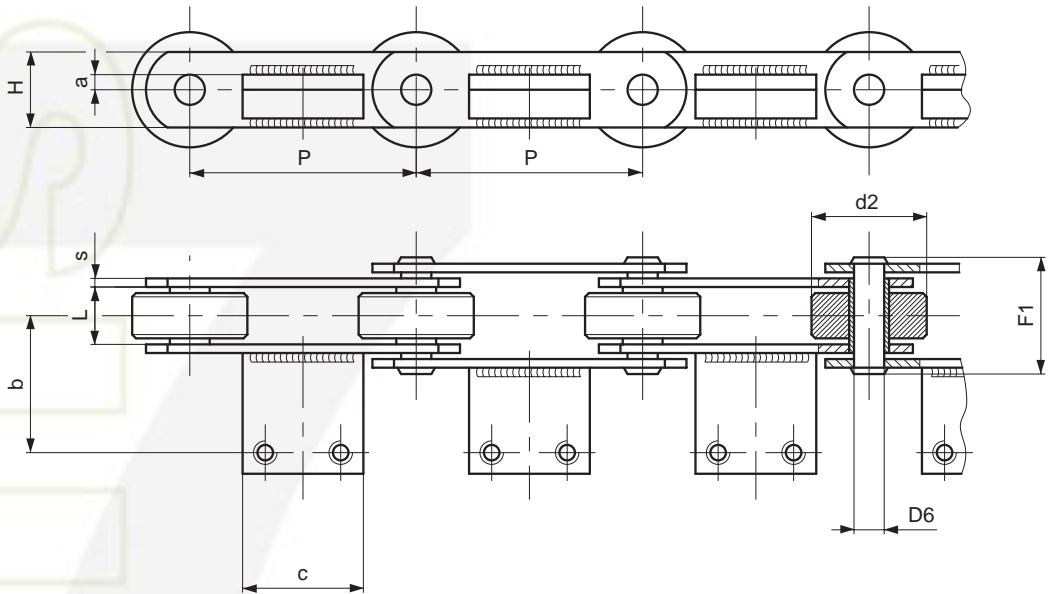

SOLID PIN CHAINS

Chain N.	P mm	L mm	D2 mm	D6 mm	H mm	S mm	F1 mm	a mm	b mm	c mm	 Breaking load N	Notes
W1596	75	22	45	12	35	4	43	17,5	50	50	100.000	Bent attachments
W2224	100	22	60	18	40	4	43,5	6	45	50	115.000	
W3636	100	22	18	12	30	4	43,5	/	/	/	64.000	Without attachments
W3030	100	25	60	14	50	5	57,5	/	/	/	150.000	Without attachments
W4983	100	36	65	22	50	6	75	4	45	60	190.000	
W2784	100	40	60	18	40	6	71	6	58	60	150.000	
W5062	100	40	60	18	40	6	71	6	58	50	150.000	
W4034	125	22	40	12	30	4	43,5	15	77	80	80.000	
W4929R	125	37	70	20	50	7	78	9	/	58	260.000	Attachments without holes
W4543	355,6	49	60	16	40	6	80,5	1	63,5	283	140.000	



CHAINS FOR SPECIAL APPLICATIONS – FOOD OVENS

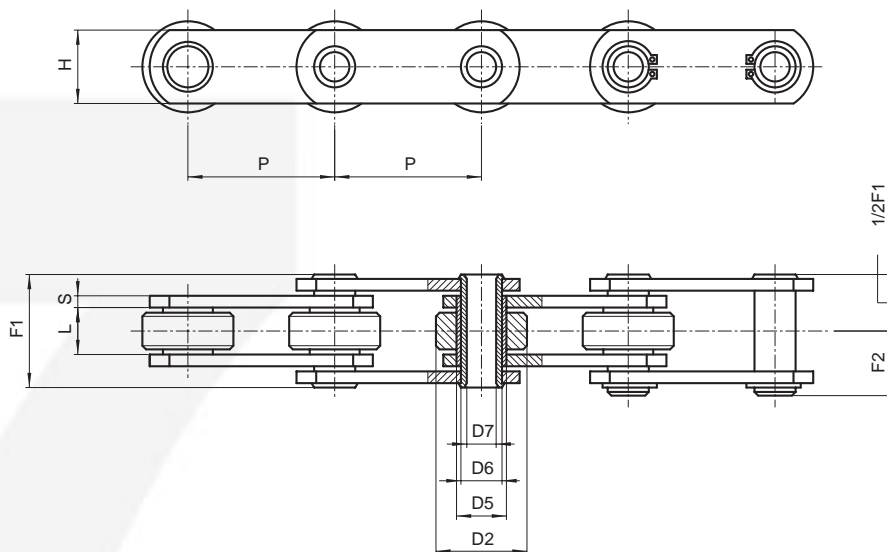

HOLLOW PIN CHAINS

Chain N.	P mm	L mm	D2 mm	D5 mm	D6 mm	D7 mm	H mm	S mm	F1 mm	F2 mm	Breaking load N	Notes
W1368	50	11,5	31,75	17,12	10	9,7	25	3	28	17,1	40.000	**
500CRP	50	15	31	17	14	10,2	25	4	35	19,5	65.000	
W3835	75	22	45	24	18	12,4	35	4	44	27,5	120.000	***
W2467	100	25	60	26	18	10,2	40	5	51	33	135.000	
W4858	100	36	65	30,8	22	10,5	50	6	75	/	190.000	
W4445	152,4	25,4	64	31,8	25	19,5	50	7/5	56	30	150.000	

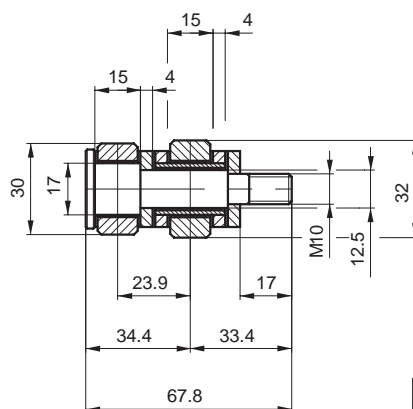
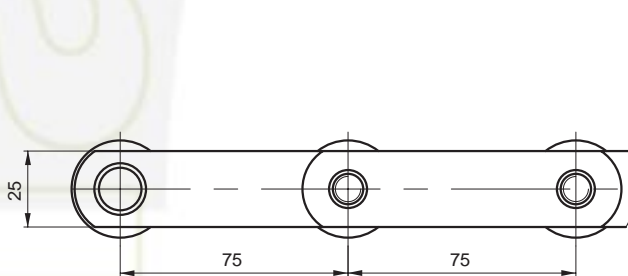

BREAD BAKING

Chain P. 75x15x32 øR

Lubrication and maintenance free through MECASEC® (registered trade mark by P.T.F.E. Sarl)

Working temperature: 250-300°C.

** Chain with solid pins and hollow pins every ...links

*** Hollow pins every 3 links



CHAINS FOR SPECIAL APPLICATIONS – FOOD OVENS

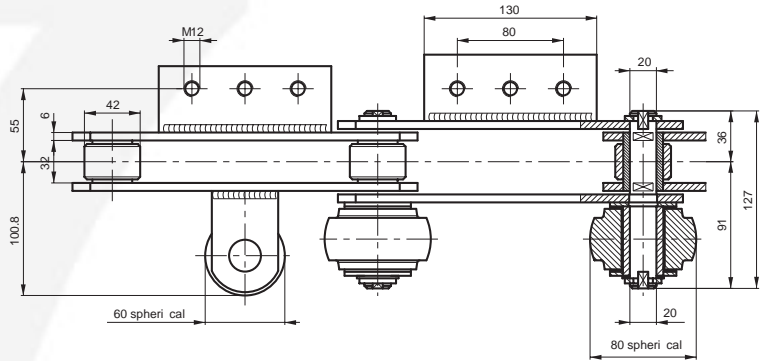
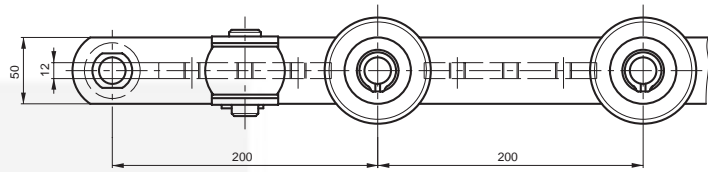

BREAD BAKING

Chain P. 200x32x42 øR

Working temperature: 250-300°C

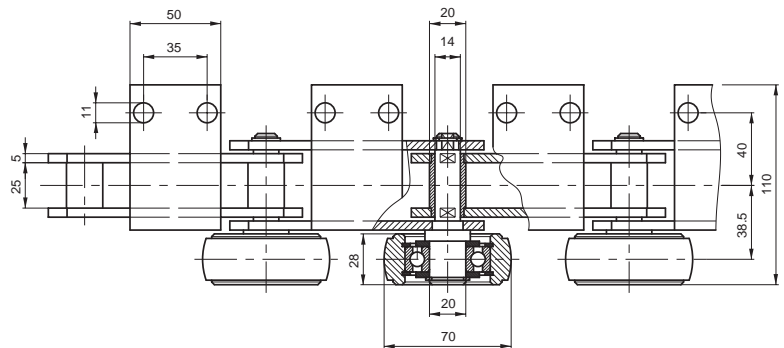
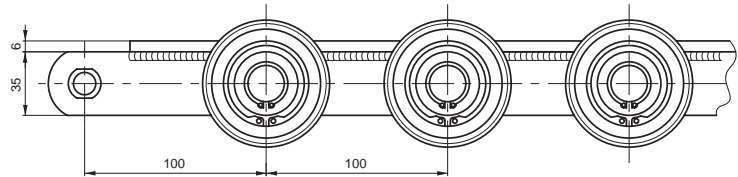

PIZZA OVENS

Chain P. 100x25x22 øRB

Working temperature: 350-400°C



CHAINS FOR SPECIAL APPLICATIONS – BOTTLE WASHING INDUSTRY

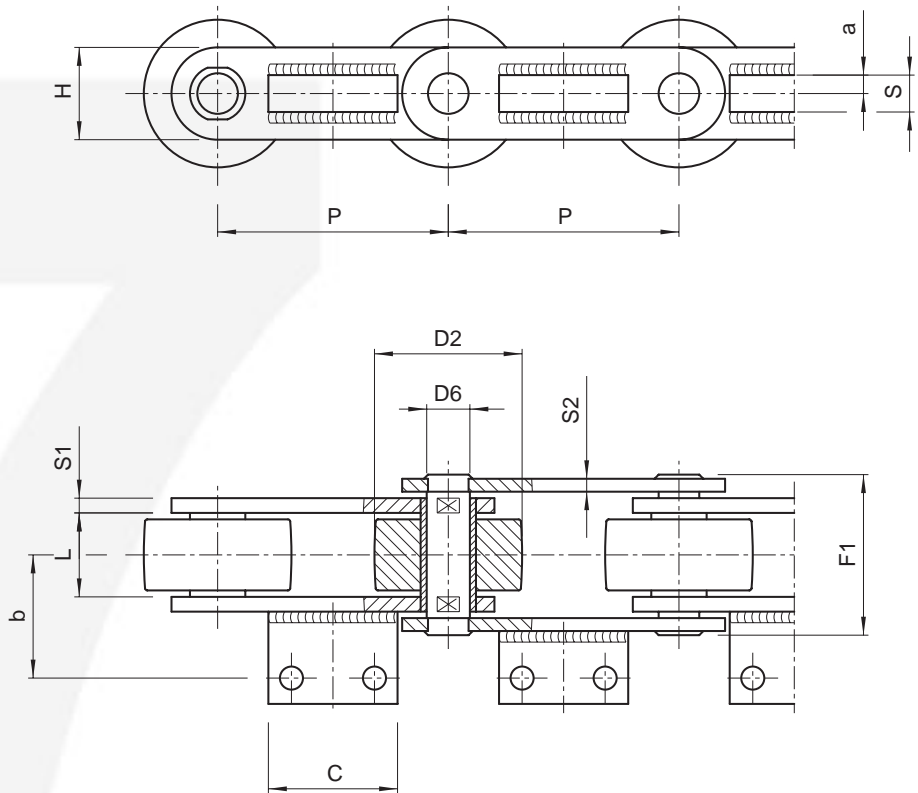

BOTTLE WASHING

Chain N.	P mm	L mm	D2 mm	D6 mm	H mm	S1/S2 mm	F1 mm	a mm	b mm	c mm	s mm	 Breaking load N	Attachment type
W4020CR*	125	42	80	22	50	7/8	79	10	65	70	20	200.000	A2-01
W3820	135	25	75	22	50	5/7	54	25	47	75	5	156.000	A2-01
W4021CR*	140	42	80	22	50	7/8	79	10	65	80	20	200.000	A2-01
W3834	150	25	80	22	50	5/7	54	30	48	80	5	156.000	A2-01
W3819	150	37	90	18	50	7	70	25	52	80	15	160.000	A2-01
W4022CR*	150	42	80	22	50	7/8	79	10	65	90	20	200.000	A2-01
W4502	160	43	85	21	60	8	84	0	64,5	80	20	300.000	A2-01
W4023CR*	173	42	80	22	50	7/8	79	10	65	90	20	200.000	A2-01
W4024CR*	203,2	42	80	22	50	7/8	79	10	65	90	20	200.000	A2-01

* alternative solutions with L = 32 mm



CHAINS FOR SPECIAL APPLICATIONS – BRICK INDUSTRY

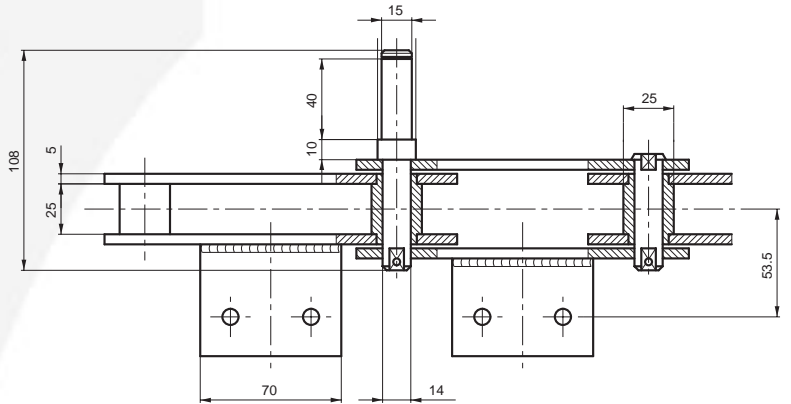
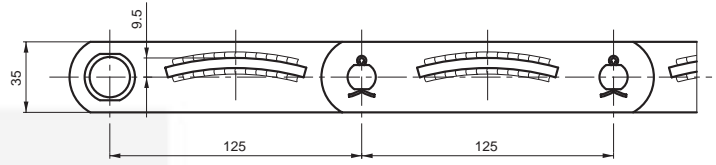

Chain P. 125x25x25 øB

 Breaking load: 100.000 N

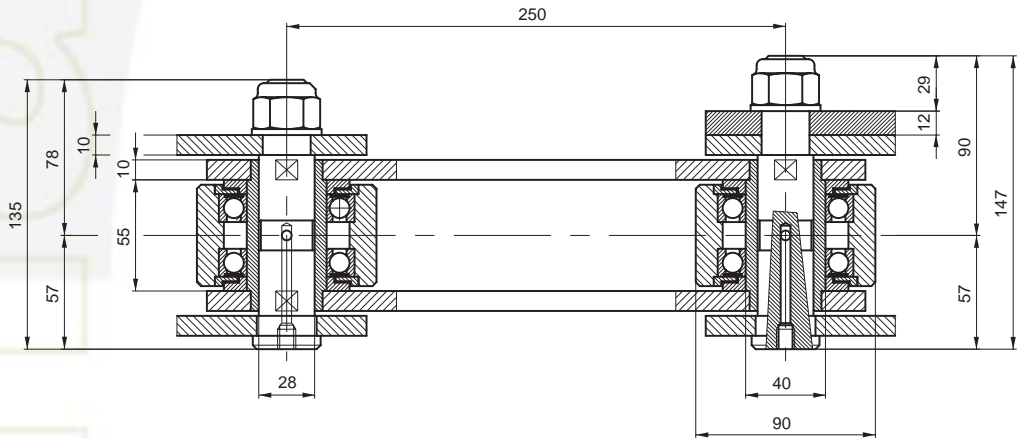

SHOVEL
EXCAVATORS

Chain P. 250x55x90 øR

 Breaking load: 500.000 N



CHAINS FOR SPECIAL APPLICATIONS – AGRICULTURAL MACHINES

ROUND BALERS

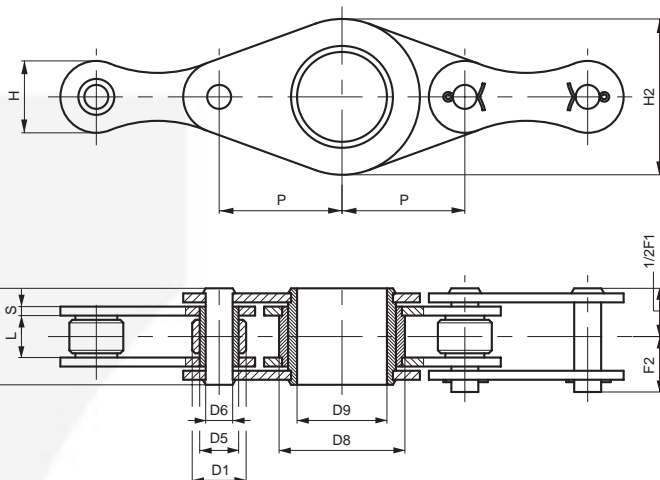

Chain N.	P mm	L mm	D1 mm	D5 mm	D6 mm	H mm	H2 mm	S mm	D8 mm	D9 mm	F1 mm	F2 mm	Breaking load N	Notes
A5080..	50,8	20	19	13,2	9,6	25,5	63	4	48	35,5	40,5	24	100.000	Attachment every 6 links
A508004..	50,8	20	19	13,2	9,6	25,5	63	4	48	35,5	40,5	24	100.000	Attachment every 4 links

LOADING FORAGE FEEDING

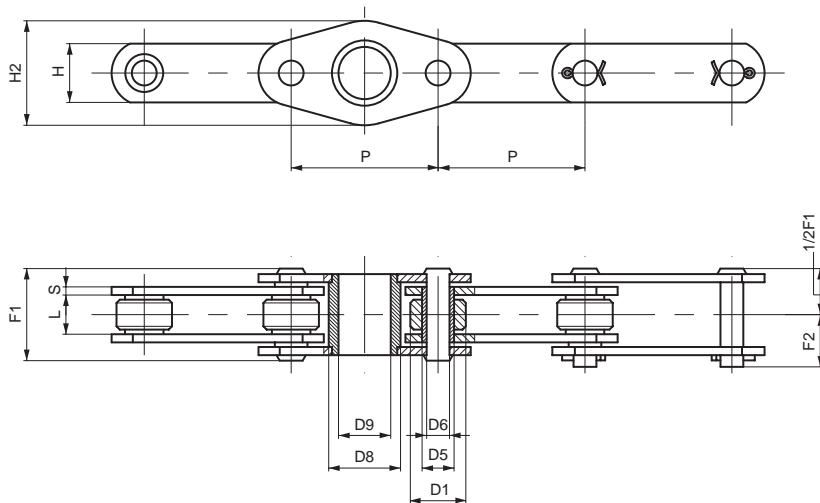

Chain N.	P mm	L mm	D1 mm	D5 mm	D6 mm	H mm	H2 mm	S mm	D8 mm	D9 mm	F1 mm	F2 mm	Breaking load N	Notes
A7020..	70	15	20	13,2	10	25	46	4	32	26	36,6	21	100.000	Attachment every 6 links
A702002..	70	15	20	13,2	10	25	46	4	32	26	36,6	21	100.000	Attachment every 2 links



CHAINS FOR SPECIAL APPLICATIONS – PATERNOSTER

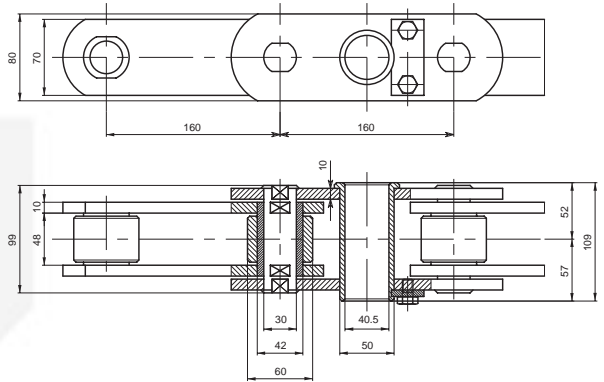

Chain P. 160x48x60 øR



Breaking load: 520.000 N

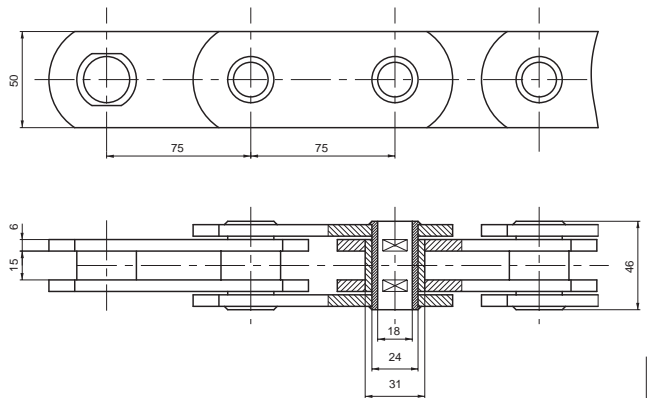

Chain P. 75x15x31 øB



Breaking load: 120.000 N

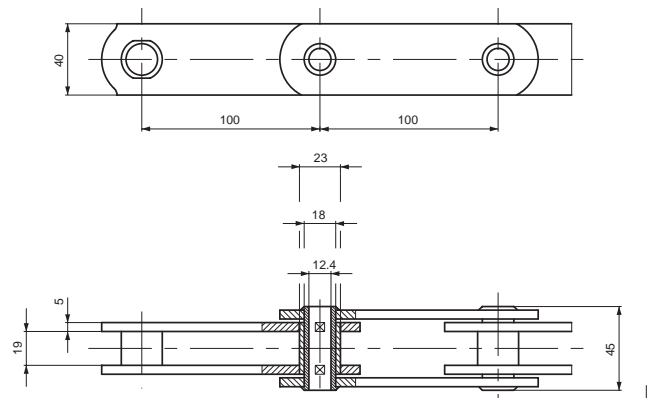

Chain P. 100x19x23 øB



Breaking load: 100.000 N



CHAINS FOR SPECIAL APPLICATIONS – FURNITURE INDUSTRY

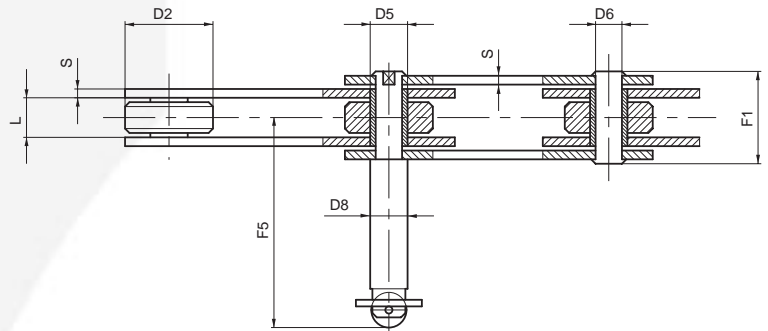
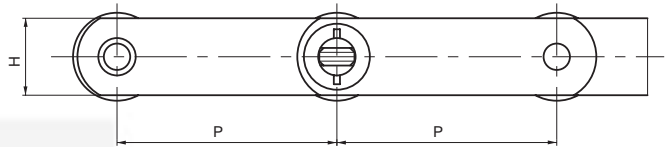

PAINT LINES

Chain N.	P mm	L mm	D2 mm	D5 mm	D6 mm	D8 mm	H mm	S mm	F1 mm	F5 mm	Breaking load N
W2030	75	18	40	17	12	17	35	4	39	94	75.000
W1555	100	18	40	17	12	17	35	4	39	94	75.000

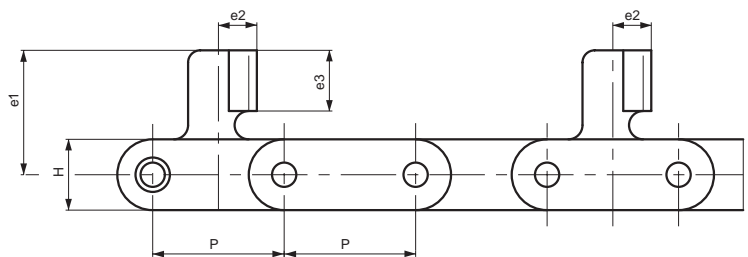

DRYING

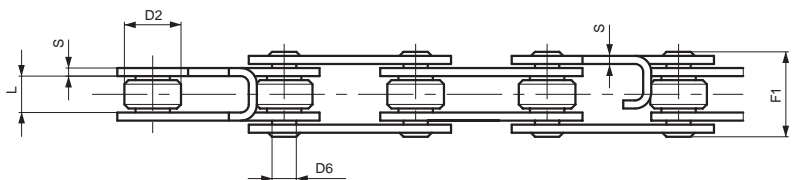

Chain N.	P mm	L mm	D2 mm	D6 mm	H mm	S mm	F1 mm	e1 mm	e2 mm	e3 mm	Breaking load N
W2439	65	18	28	12	35	4	39	55,5	8	25	125.000
W2120R	75	15	40	12	35	4	36,5	55,5	8	25	125.000
W1127R03	65	18	28	12	35	4	40	61,5	12	30	125.000
W2756R	60	15	31	12	35	4	36	55,5	8	25	125.000



CHAINS FOR SPECIAL APPLICATIONS – POLYURETHANE PANEL APPLICATIONS

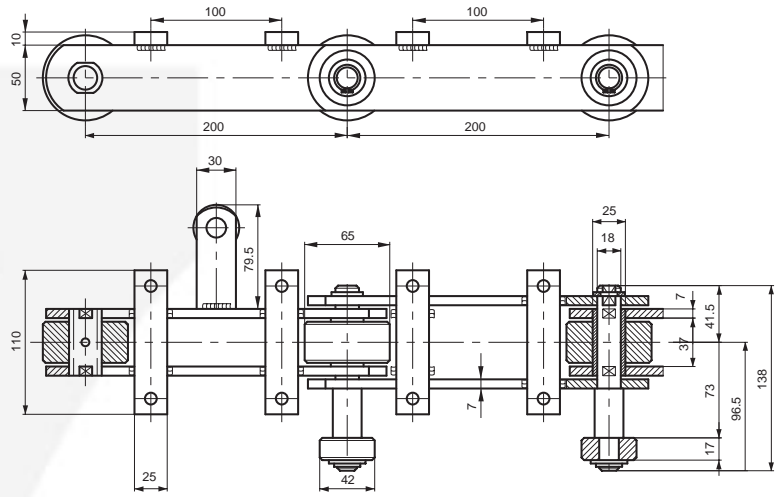

CONDITIONING TUNNEL

Chain P. 200x37x65 øR

 Breaking load: 210.000 N

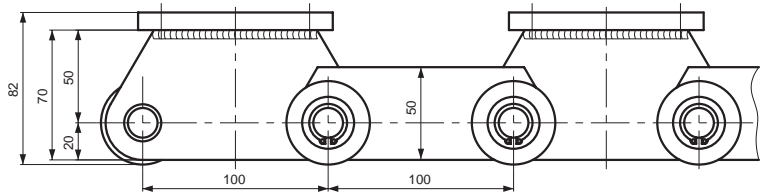

CONDITIONING TUNNEL

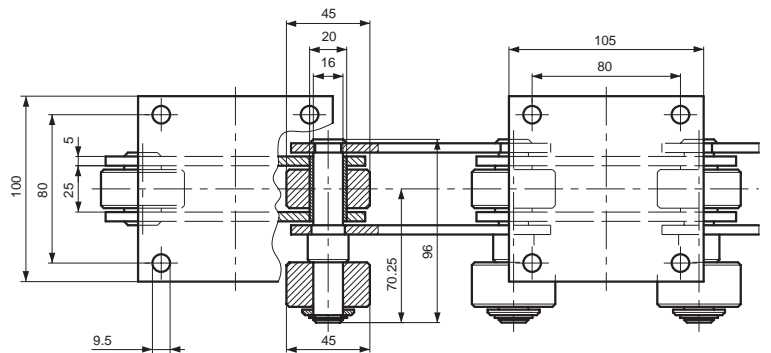

Chain P. 100x25x45 øR

 Breaking load: 210.000 N



CHAINS FOR SPECIAL APPLICATIONS – WASTE PAPER AND WASTE RECYCLING INDUSTRY

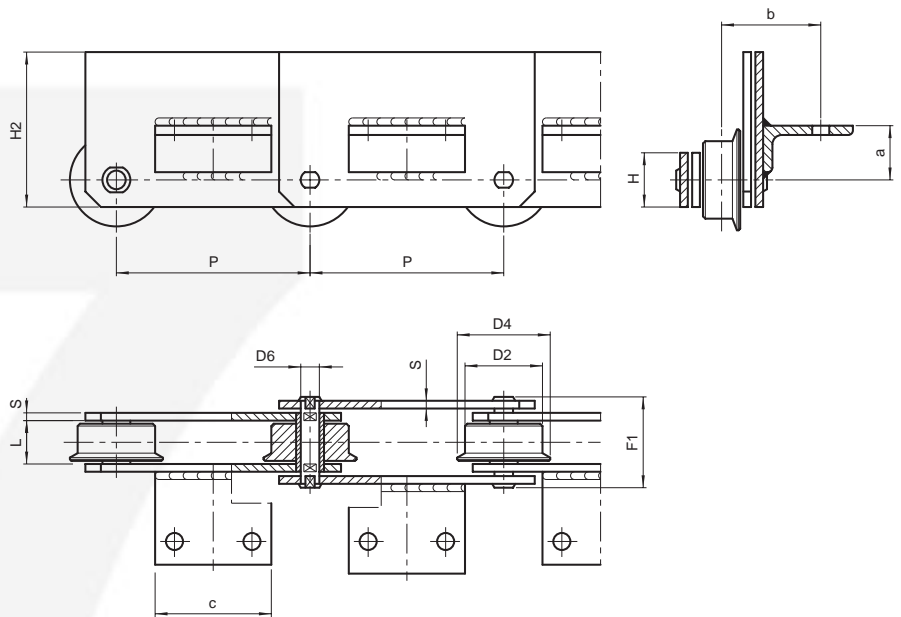

SOLID PIN CHAINS

Chain N.	P mm	L mm	D2 mm	D4 mm	D6 mm	H mm	H2 mm	S mm	a mm	b mm	F1 mm	Breaking load N	Attachment type
W1743	100	24	40	/	12	35	/	4	26	38,5	45	75.000	A1-01
W4563•	125	25	40	/	14	35	/	5	-2,5	41	51,5	100.000	A2-01
W4122	125	28	50	65	12	35	100	5	35	64	54,5	80.000	A2-01
W4123•	125	28	50	65	12	35	100	5	-5	64	54,5	80.000	A2-01
W4122A	125	28	50	65	12	35	100	5	35	48	54,5	80.000	A2-01
W4123A•	125	28	50	65	12	35	100	5	-7	48	54,5	80.000	A2-01
W4123B••	125	28	50	65	12	35	100	5	-7	48	54,5	80.000	A2-02
W3946	200	32	60	/	15	40	90	6	/	/	63	112.000	without attachments
W3946R	200	32	60	75	15	40	90	6	/	/	63	180.000	without attachments
W4587	200	36	65	80	20	50	100	8	26	70	77	175.000	A2-01
W4124	200	37	70	90	18	50	120	7	55	80	72	160.000	A2-01
W4125•	200	37	70	90	18	50	120	7	-5	80	72	160.000	A2-01
W4639•	200	37	70	90	18	50	80	7	-10	80	72	160.000	A2-01
W4124R	200	37	70	90	18	50	120	7	55	80	72	260.000	A2-01
W4125R•	200	37	70	90	18	50	120	7	-5	80	72	260.000	A2-01

* angle only on the inner links

• position of the attachment under the center line of chain



CHAINS FOR SPECIAL APPLICATIONS – GRAIN CONVEYORS DIN 8167

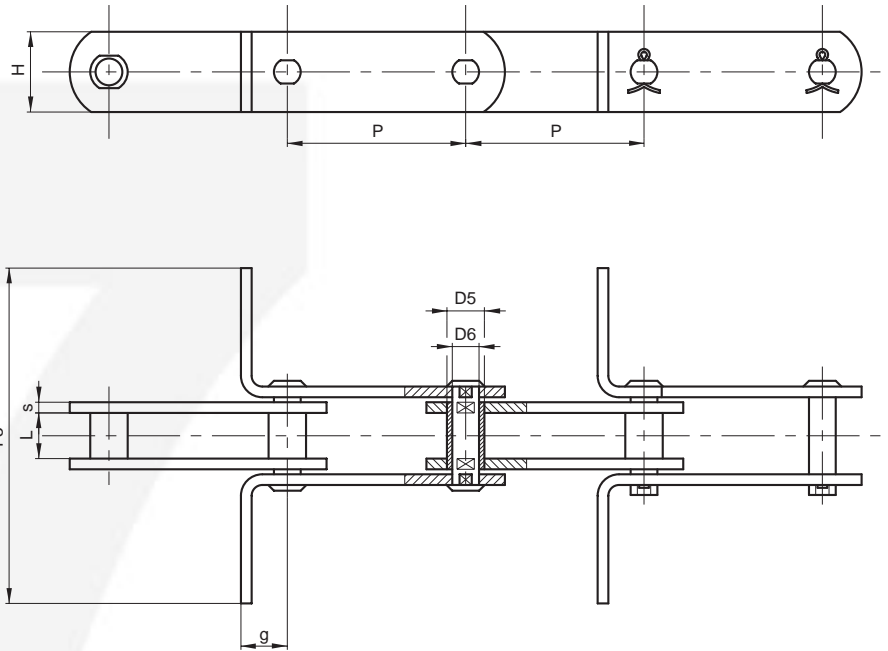

SCRAPER CHAINS

Chain N.	P mm	L mm	D5 mm	D6 mm	H mm	s mm	g mm	F3 mm	Breaking load N	Chain weight kg/m ●
MR56	100	24	15	10	30	4	20	*	56.000	2,8
"	125	24	"	"	"	"	"	*	"	2,6
MR80	100	28	18	12	35	5	25	*	80.000	4,3
"	125	28	"	"	"	"	"	*	"	4
"	150	28	"	"	"	"	"	*	"	3,7
MR112	100	32	21	15	40	6	35	*	112.000	6,2
"	125	32	"	"	"	"	"	*	"	5,7
"	150	32	"	"	"	"	"	*	"	5,3
MR160	100	37	25	18	50	7	40	*	160.000	9,7
"	125	37	"	"	"	"	"	*	"	8,9
"	150	37	"	"	"	"	"	*	"	8,2
MR224	125	43	30	21	60	8	44	*	224.000	13
"	150	43	"	"	"	"	"	*	"	12
"	200	43	"	"	"	"	"	*	"	11
MR315	150	48	36	25	70	10	50	*	315.000	18,3
"	200	48	"	"	"	"	"	*	"	16,7
"	250	48	"	"	"	"	"	*	"	15,6

Additional features:
 - cottered on one or both sides
 - with holes in scrapers
 - stainless steel

● without scrapers
 * free dimensions



CHAINS FOR SPECIAL APPLICATIONS – GRAIN CONVEYORS DIN 8165

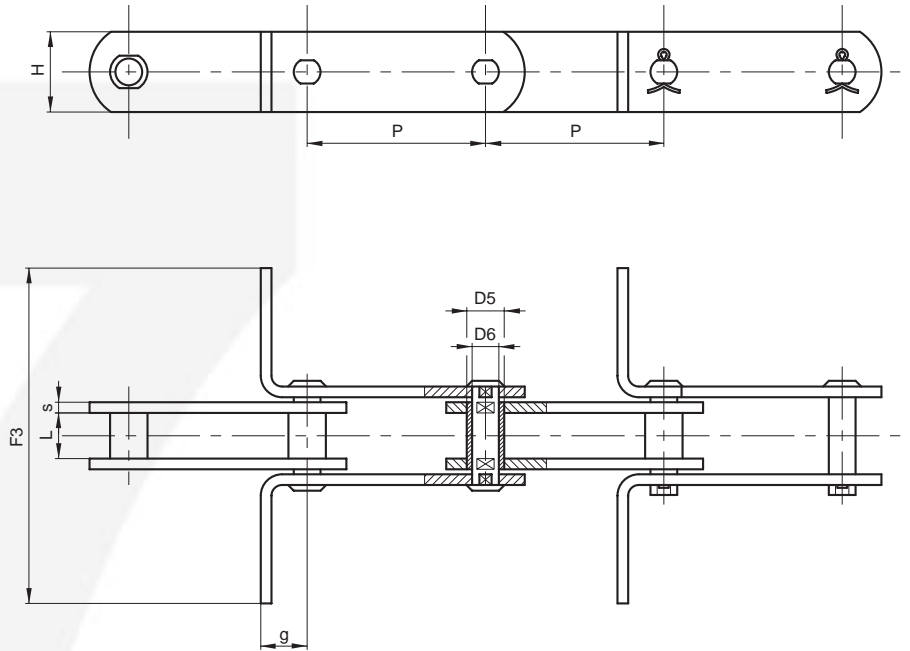

SCRAPER CHAINS

DIN N.	Chain N.	P mm	L mm	D5 mm	D6 mm	H mm	s mm	g mm	F3 mm	Breaking load N	Chain weight kg/m ●
FV40	CR42	80	18	15	10	25	3	25	*	42.000	1,9
"	"	100	"	"	"	"	"	"	*	"	1,7
"	"	125	"	"	"	"	"	"	*	"	1,6
FV63	CR64	100	22	18	12	30	4	25	*	64.000	3
"	"	125	"	"	"	"	"	"	*	"	2,7
"	"	150	"	"	"	"	"	"	*	"	2,4
FV90	CR100	100	25	20	14	35	5	30	*	100.000	4,5
"	"	125	"	"	"	"	"	"	*	"	4,2
"	"	150	"	"	"	"	"	"	*	"	4
FV112	CR120	100	30	22	16	40	6	35	*	120.000	6,7
"	"	125	"	"	"	"	"	"	*	"	6
"	"	150	"	"	"	"	"	"	*	"	5,5
FV140	CR145	100	35	26	18	45	"	38	*	145.000	7,4
"	"	125	"	"	"	"	"	"	*	"	6,7
"	"	150	"	"	"	"	"	"	*	"	6
FV180	CR190	125	45	30	20	50	8	44	*	190.000	10,5
"	"	150	"	"	"	"	"	"	*	"	10,2
"	"	200	"	"	"	"	"	"	*	"	9,6
FV250	CR275	125	55	36	26	60	"	50	*	275.000	13,4
"	"	150	"	"	"	"	"	"	*	"	12,3
"	"	200	"	"	"	"	"	"	*	"	11,3

Additional features:
 - cotted on one or both sides
 - with holes in scrapers
 - stainless steel

● without scrapers
 * free dimensions



CHAINS FOR SPECIAL APPLICATIONS – TOBACCO

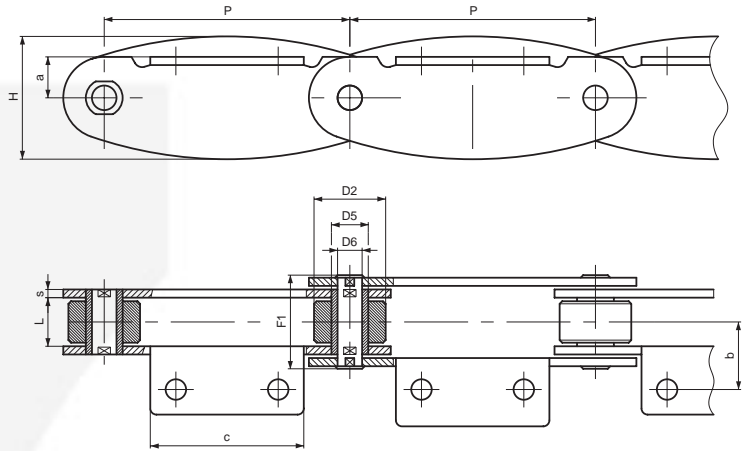

Chain N.	P mm	L mm	D2 mm	D6 mm	H mm	S mm	F1 mm	a mm	b mm	c mm	Breaking load N
W3571	120	22	35	12	60	4	43	20	33	75	90.000

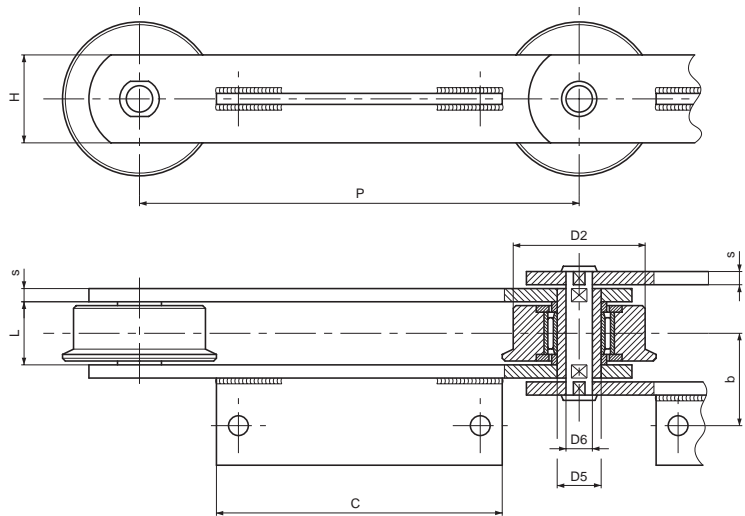

Chain N.	P mm	L mm	D2 mm	D6 mm	H mm	S mm	F1 mm	a mm	b mm	c mm	Breaking load N
W3616	200	28	60/70	12	40	5	55	2,5	42	130	60.000
W4088A	200	28	50/60	14	40	5	55	-2,5	40	110	130.000
W3840R**	200	37	60/70	20	40	5	64	2,5	46,5	130	150.000
W4919SS*	200	37	60/70	15	40	5	64	2,5	46,5	130	90.000
W4664	200	38	67/82	15	45	6	69	-2,5	47	110	180.000

* chain in stainless steel
 ** without needle casing



CHAINS FOR SPECIAL APPLICATIONS – TOBACCO

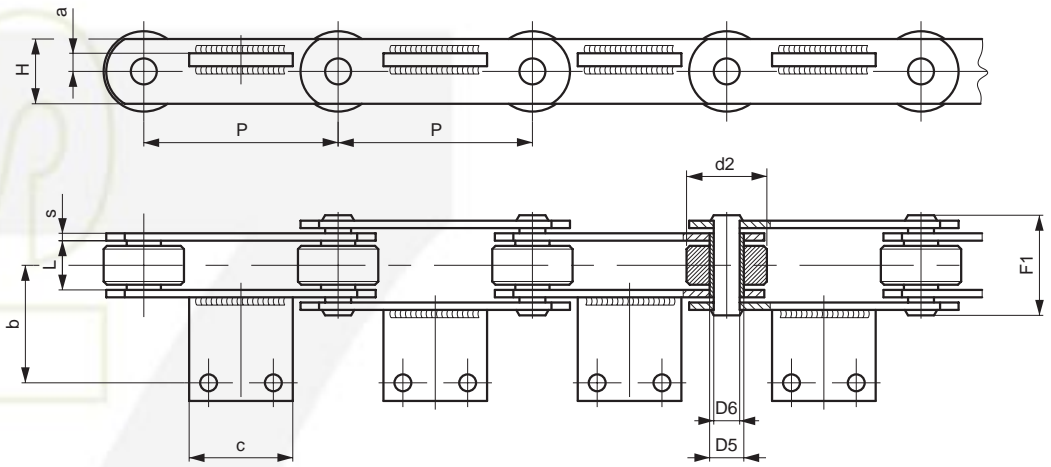

DRYING TUNNEL

Chain N.	P mm	L mm	D2 mm	D6 mm	H mm	S mm	F1 mm	a mm	b mm	c mm	Breaking load N	Notes
W3977	75	15	31	10	25	4	36	7	33	40	45.000	
W1383	100	15	55	12	30	4	36	23	40	50	70.000	
W4010	100	26,5	50	12,6	35	5	54	6	41,5	55	100.000	
W3596R	100	26,5	50	12	35	5	54	-14	49,5	35	100.000	
W3458R	100	28	50	14,4	35	5	54,5	14	49,5	35	130.000	
W2988CR	200	26,5	60	16	40	5	54	2,5	43,5	130	150.000	
W2520	200	28	65	18	50	6	59	13	53	60	160.000	
W4088	200	28	50/60	12	40	5	59	-2,5	40	110	100.000	flanged roller
W3808	200	37	70	18	50	7	72	3	62	115	260.000	
W3840R	200	37	60/70	12,4	40	5	63,5	2,5	46,5	130	110.000	flanged roller
W3782	200	38,5	100/112	30	80	10/12	91	3	73	95	850.000	flanged roller
W3790	200	38,5	100/112	36	90	12	97	-3,5	73	95	1.600.000	flanged roller



CHAINS FOR SPECIAL APPLICATIONS – SWARF HANDLING

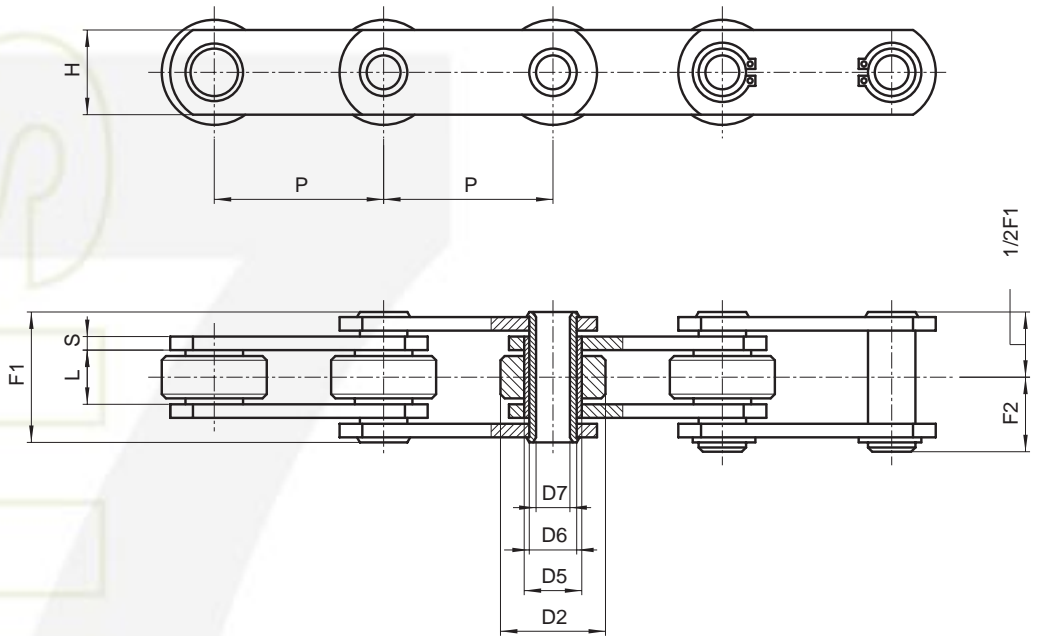

HOLLOW PIN CHAINS

Chain N.	P mm	L mm	D2 mm	D5 mm	D6 mm	D7 mm	H mm	S mm	F1 mm	F2 mm	Breaking load N	Chain weight kg/m
C2059	31,75	9,53	19,05	10,2	7,02	5,12	15	2	20,1	11,5	19.600	1,2
W2056	38,1	12,7	22,23	11	9	6,2	18	2,5	25,5	13,75	26.500	1,9
3520Z	35	16	20	17	14	10,2	26	2,5	30	16,7	25.000	2,2
W1667	40	9	22	12	9	6,2	18	2,5	23	13	15.500	1,7
W1948	40	13	25	15	12	8,9	22	3	29	16,7	21.000	2,4
400C ♦	50	15	31	17	14	10,2	25	3	31	17,5	35.000	3
W3635	50	15	31	17	14	10,2	25	3	31	17,5	35.000	3
500C	50	15	31	17	14	10,2	25	4	35	19,5	40.000	3,6
500CSS*	50	15	31	17	14	10,5	25	4	36	19,5	35.000	3,6
W4086Z	50	15	40	17	14	10,5	25	4	36	19,5	40.000	3,8
W2795	50	11,5	25	16	13,2	10,5	23	2,5	25	15	16.000	1,8
W2137R	63	15	40	/	16	12,3	28,5	4	35	20	80.000	4,7
W4601	63	21,5	40	/	16	10,5	28,5	4	42	22	50.000	4,7
W5048	63	18	40	17	14	10,2	28	4	38	20,5	50.000	4,1
6540C	65	18	40	17	14	10,2	25	4	38	21	40.000	4,8
701C	75	22	40	23	18	12,2	35	4	42	24	60.000	4,6
W4671R	75	18	40	/	20	15,2	30	4	38,5	21,5	55.000	4,7
703C	100	22	40	23	18	12,2	35	4	42	24	60.000	4,6
704C	125	22	40	23	18	12,2	35	4	42	24	60.000	4,2
W1521/1 ▲	125	30	60/76	25	20	14,5	40	5	56	31	70.000	9
ZC150C1524X	152,4	25,4	66,7	33	26,9	20,1	50	7/5	58	34,5	150.000	9,7

- * stainless steel chain
- ♦ chain with shaped plates
- ▲ chain with flanged rollers



CHAINS FOR SPECIAL APPLICATIONS – SWARF HANDLING

SOLID PIN CHAINS

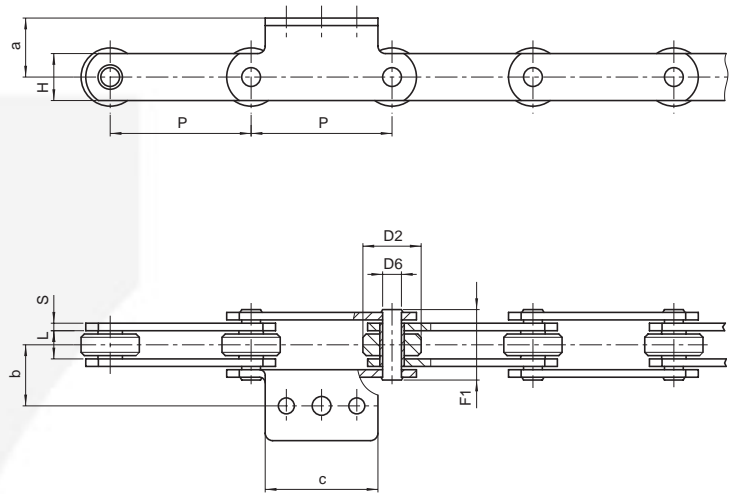

Chain N.	P mm	L mm	D2 mm	D6 mm	H mm	S mm	F1 mm	a mm	b mm	c mm	Breaking load N	Chain weight kg/m
C2052A204	31,75	9,6	19	5,1	15,1	2	20,4	11,1	15,9	25,4	26.500	1,3
W4218	42	22	18	5,7	20	4	42,5	35	45	30	32.000	2,9
500	50	15	31	10	25	4	36,6	22	45	45	45.000	3,9
205BA108	50	11,5	25	5,7	18	2,5	25,9	14	33	46	18.000	1,8
703BA310	100	22	40	12	35	4	44	26	38	70	75.000	5

SOLID PIN CHAINS

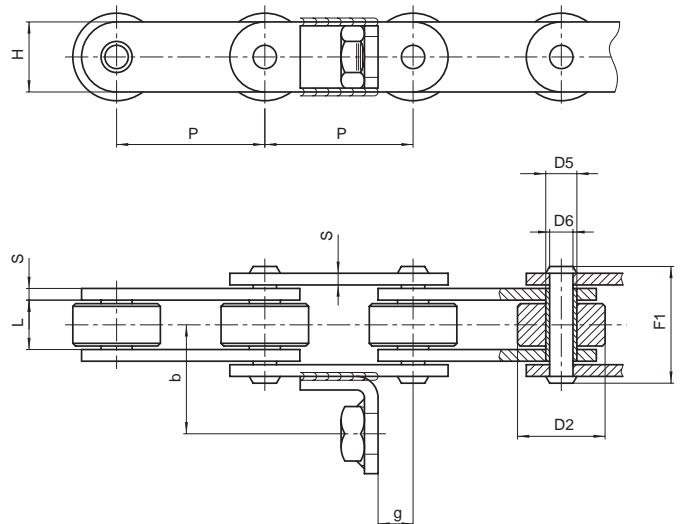

Chain N.	P mm	L mm	D2 mm	D5 mm	D6 mm	H mm	S mm	F1 mm	g mm	b mm	Breaking load N	Chain weight kg/m
W1949AR	38,1	12,7	22,2	8	6	18	3	30	9	28	38.000	3,3
W4584	63	22	40	17	12	30	4	43	16,5	34	66.000	6,1



CHAINS FOR SPECIAL APPLICATIONS – FREEZING TUNNELS

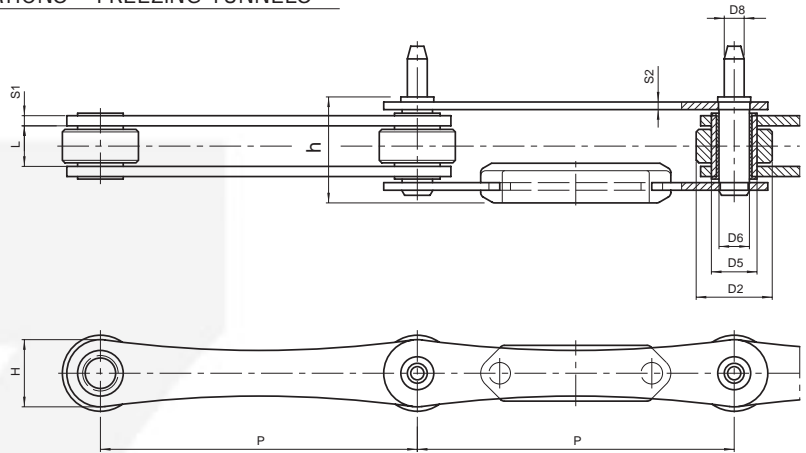

HARDENING
TUNNEL

Chain N.	P mm	L mm	D2 mm	D5 mm	D6 mm	D8 mm	H mm	S1/S2 mm	h mm	Breaking load N
W4577*	63,5	10	30	18	10	7,9	26,5	3	31,2	30.000
W5071*	95,25	16	30	18	11,9	9	26,5	4/3	36,8	40.000
W4530*	125	14	30	18	11,8	7,9	26,5	4/3	36,5	45.000
W4578*	125	16	30	18	11,8	7,9	26,5	4/3	39,8	40.000
W4967*	127	10	30	16	11,5	7,9	26,5	3	31,3	30.000
W4899*	150	16	30	18	11,9	7,9	26,5	4/3	42,8	40.000

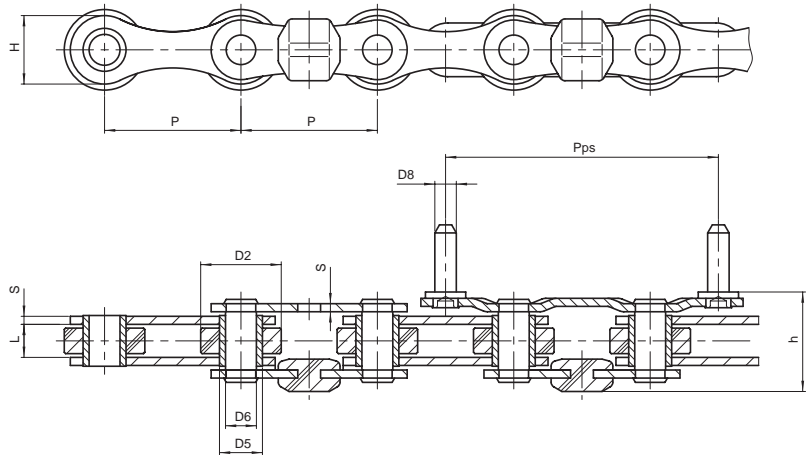

HARDENING
TUNNEL

Chain N.	P mm	L mm	D2 mm	D5 mm	D6 mm	D8 mm	H mm	S mm	h mm	Pps mm	Breaking load N
W4813*	50,8	10	30	16	11,5	8	25,2	3	29,3	101,6	34.000

* stainless steel chain



CHAINS FOR SPECIAL APPLICATIONS – FREEZING TUNNELS

HARDENING TUNNEL

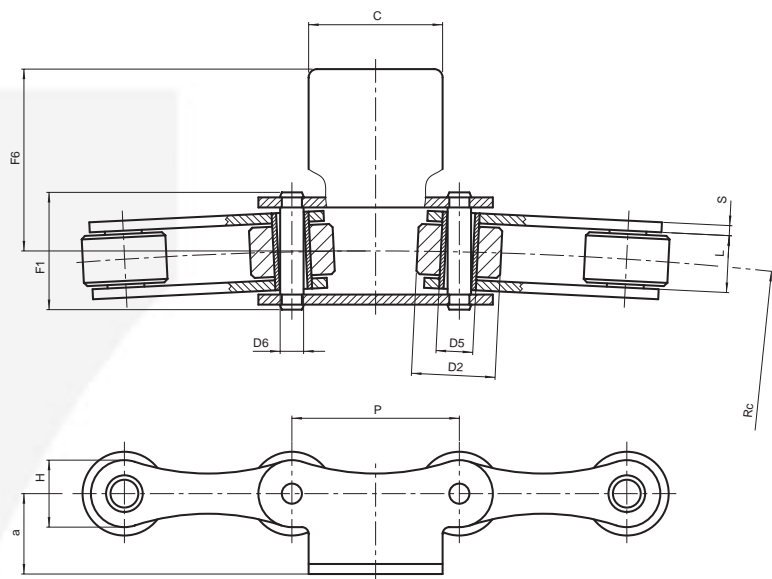

Chain N.	P mm	L mm	D2 mm	D5 mm	D6 mm	H mm	S mm	F1 mm	a mm	c mm	F6 mm	 Breaking load N	Notes
W1947*	50	17	25	11	7	20	3	33,5	-24	40	54	30.000	attachm. position variable

HARDENING TUNNEL

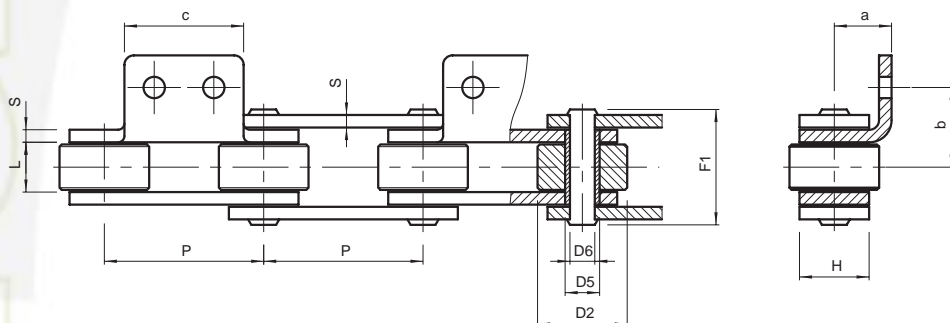

Chain N.	P mm	L mm	D2 mm	D5 mm	D6 mm	H mm	S mm	F1 mm	a mm	b mm	c mm	 Breaking load N
W4528ASS*	50,8	15,9	28,6	11	7,9	22,2	4	36,5	18,25	25,4	38	25.000
W4528PSS*	50,8	15,9	28,6	11	7,9	22,2	4	36,5	18,25	17,5	38	25.000

* stainless steel chain



CHAINS FOR SPECIAL APPLICATIONS – SLIDING CHAIN CONVEYORS

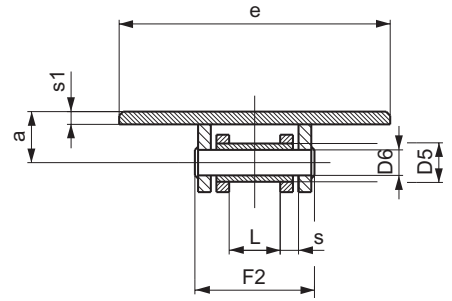
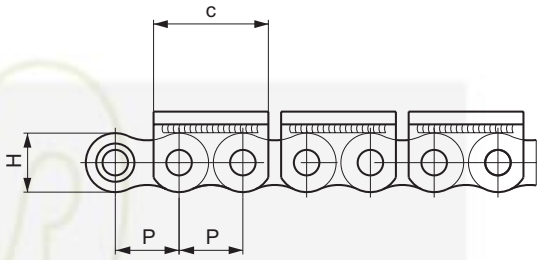

SOLID PIN CHAINS

Chain N.	P mm	L mm	D5 mm	D6 mm	H mm	S mm	F2 mm	a mm	c mm	e mm	s mm	Breaking load N	Chain weight kg/m
TB85	20	16	12	8	18,5	3	36	15,5	36	85	4	20.000	4,7

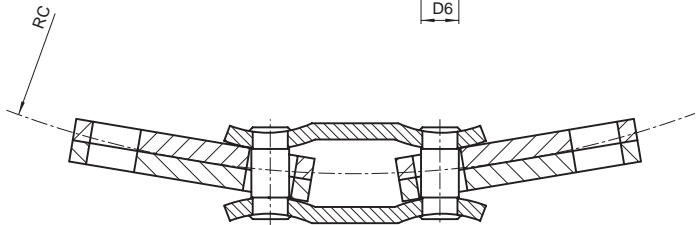
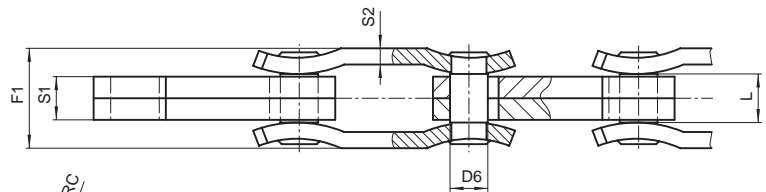
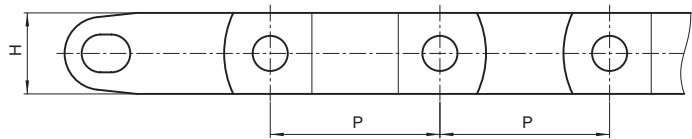

SOLID PIN CHAINS

Chain N.	P mm	L mm	D6 mm	H mm	S1 mm	S2 mm	F1 mm	** RC mm	Breaking load N	Chain weight kg/m
6285	62,85	18	14	30	16	6	38	400	130.000	5,1

** RC minimum radius of curvature



CHAINS FOR SPECIAL APPLICATIONS – SIDEBOW CHAIN CONVEYORS

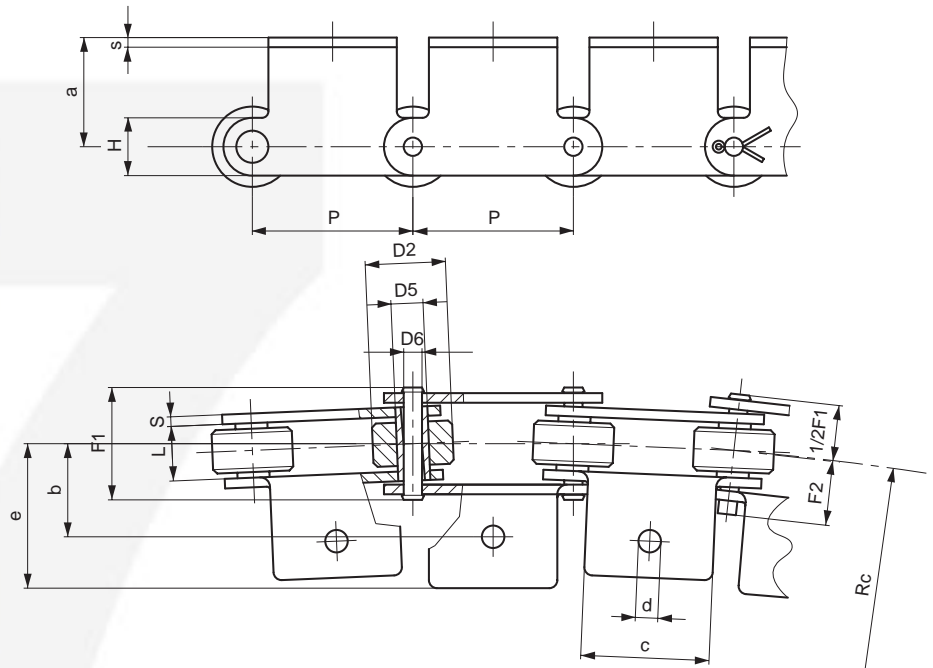

SOLID PIN CHAINS

Chain N.	P mm	L mm	D2 mm	D5 mm	D6 mm	H mm	S mm	F1 mm	F2 mm	** RC mm	 Breaking load N	Chain weight kg/m
C50	50	17	25	10	5,9	18	3	35	20	900	20.000	2,4
C65	65	17	25	10	5,9	18	3	35	20	1200	20.000	2

ATTACHMENTS

Chain N.	P mm	a mm	b mm	c mm	d mm	e mm	s mm	Weight per attach. kg
C50	50	34	29	40	7	45	3	0,045
C65	65	34	29	50	7	43	3	0,055

** RC minimum radius of curvature



OUR LOCATION



HOW TO REACH US



SPROCKETS

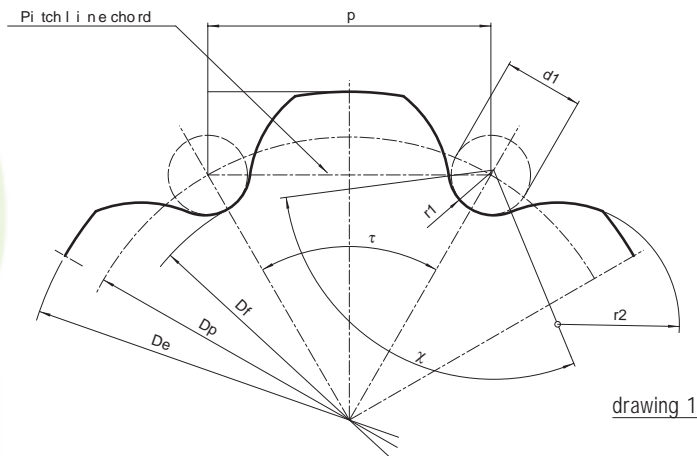

drawing 1

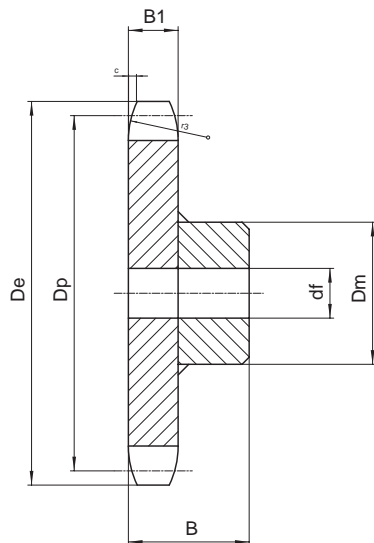

drawing 2

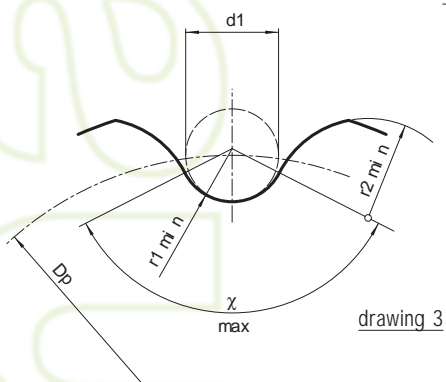

drawing 3

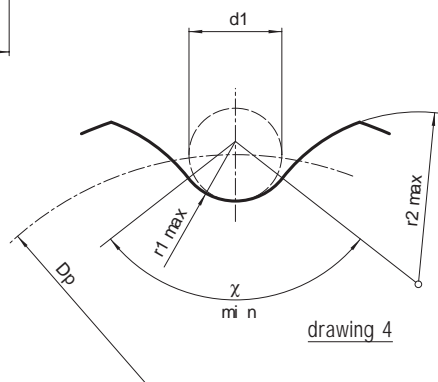

drawing 4

LEGENDA

p chain pitch
 d_1 roller diameter
 D_p pitch diameter
 D_f bottom-land diameter
 D_e outer diameter

r_1 radius of the roller seat
 τ pitch angle
 χ angle of the roller seat
 r_2 radius of the tooth flank

z number of teeth
 B_1 tooth width
 c release of the tooth flank
 r_3 radius of the tooth head

SPROCKETS

For the dimensioning of the sprockets we propose the following calculation scheme. The suggested method obviously can not satisfy all possible needs, but it wants to be only a guiding trail to the project of these elements.

PITCH DIAMETER (See drawings 1-2)

$$D_p = \frac{P}{\sin \frac{\tau}{2}} = p \cdot y$$

$$\frac{\tau}{2} = \frac{180^\circ}{z}$$

y = fixed number of table no.8

TABLE 8

No. of Theet	Fixed no. y	No. of Theet	Fixed no. y	No. of Theet	Fixed no. y
6	2,000	21	6,709	36	11,474
7	2,305	22	7,027	37	11,792
8	2,613	23	7,344	38	12,110
9	2,924	24	7,661	39	12,428
10	3,236	25	7,979	40	12,745
11	3,549	26	8,296	41	13,063
12	3,864	27	8,614	42	13,381
13	4,179	28	8,931	43	13,700
14	4,494	29	9,249	44	14,018
15	4,810	30	9,567	45	14,336
16	5,126	31	9,885	46	14,654
17	5,442	32	10,202	47	14,972
18	5,759	33	10,520	48	15,290
19	6,076	34	10,838	49	15,608
20	6,392	35	11,156	50	15,926

DIAMETER OF THE TOOTH BOTTOM (See drawing 1)

$$D_f = D_p - d_1$$

DIMENSIONS OF THE HOUSING OF THE ROLLER (See drawings 3-4)

Minimum dimensions:

$$r_{1\min} = 0,505 \cdot d_1$$

$$\chi_{\max} = 140^\circ - \frac{90^\circ}{z}$$

$$r_{2\min} = 0,12 \cdot d_1 \cdot (z+2)$$

Maximum dimensions:

$$r_{1\max} = 0,505 \cdot d_1 + 0,069 \cdot \sqrt[3]{d_1}$$

$$\chi_{\min} = 120^\circ - \frac{90^\circ}{z}$$

$$r_{2\max} = 0,008 \cdot d_1 \cdot (z^2+180)$$

OUTER DIAMETER (See drawings 1-2)

Maximum value:

$$D_e \max = D_p + 0,8 d_1$$

Minimum value:

$$D_e \min = D_p + 0,5 d_1$$

SECTION OF THE TOOTH (See drawing 2)

$$B_1 = (0,90 \div 0,93) \cdot L$$

L = inner width of the chain

$$0,1 \cdot p \leq c \leq 0,15 \cdot p$$

$$r_3 \leq p$$

STOCK SPROCKETS - CAST IRON CAST TOOTH SINGLE SIDED SOLID BOSS TO SUIT PLAIN ROLLERS

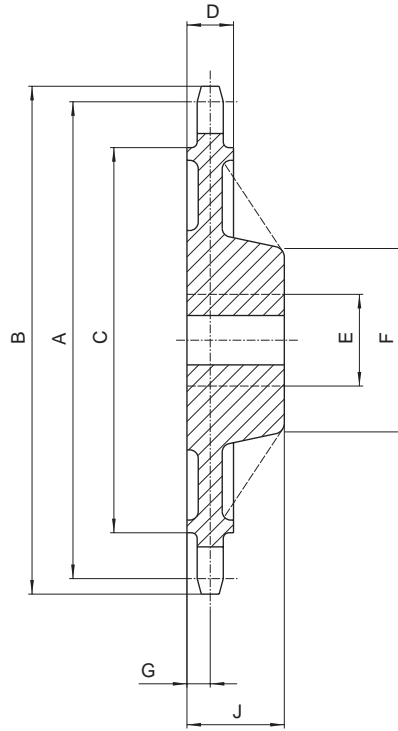

ZC21 SERIES
(4500lb)

Chain pitch (mm.)	No. of teeth	A P.C.D.	B Top Dia.	F Boss Dia.	E Max Bore	J Distance Thru'
38,1	8	99,57	105,00	57,00	32,00	38,00
"	12	147,22	157,00	76,00	38,00	45,00
50,8	8	132,74	142,00	76,00	38,00	45,00
"	12	196,27	207,00	89,00	45,00	51,00
63,5	8	165,94	175,00	76,00	38,00	45,00

Z40/ZC40 SERIES
(6000/7500lb)

Chain pitch (mm.)	No. of teeth	A P.C.D.	B Top Dia.	F Boss Dia.	E Max Bore	J Distance Thru'
50,8	6	101,60	110,83	58,00	32,00	51,00
"	8	132,74	144,00	76,00	38,00	51,00
"	12	196,29	212,00	102,00	50,00	51,00
"	14	228,29	245,00	104,00	50,00	55,00
"	16	260,40	278,00	114,00	64,00	64,00
76,2	6	152,40	166,00	93,00	50,00	55,00
"	8	199,11	215,00	102,00	50,00	51,00
"	10	246,58	264,00	114,00	65,00	64,00
"	12	294,44	314,00	114,00	65,00	64,00
"	16	390,60	413,00	140,00	70,00	76,00
101,6	8	265,48	281,00	114,00	65,00	64,00
"	10	328,78	347,00	114,00	65,00	64,00
"	12	392,56	411,00	127,00	70,00	70,00
152,4	8	398,22	414,00	127,00	70,00	70,00

STOCK SPROCKETS - CAST IRON CAST TOOTH SINGLE SIDED SOLID BOSS TO SUIT PLAIN ROLLERS

Z100/ZC60 SERIES
(12000/15000lb)

Chain pitch (mm.)	No. of teeth	A P.C.D.	B Top Dia.	F Boss Dia.	E Max Bore	J Distance Thru'
76,2	8	199,11	218,00	114,00	70,00	70,00
"	12	294,41	318,00	133,00	75,00	76,00
101,6	8	265,51	286,00	127,00	70,00	70,00
"	10	328,78	350,00	127,00	70,00	70,00
"	12	392,56	415,00	140,00	76,00	76,00
"	16	520,78	547,00	165,00	83,00	102,00
152,4	8	398,25	418,00	140,00	80,00	76,00
"	12	588,82	612,00	165,00	90,00	89,00

Z160/ZC150 SERIES
(24000/30000lb)

Chain pitch (mm.)	No. of teeth	A P.C.D.	B Top Dia.	F Boss Dia.	E Max Bore	J Distance Thru'
101,6	8	265,51	290,00	152,00	85,00	83,00
"	10	328,78	345,00	165,00	85,00	95,00
"	16	520,78	552,00	191,00	102,00	102,00
152,4	8	398,25	43,00	165,00	95,00	95,00
"	12	588,82	617,00	196,00	110,00	130,00

Z300/ZC300 SERIES
(36000/45000lb)

Chain pitch (mm.)	No. of teeth	A P.C.D.	B Top Dia.	F Boss Dia.	E Max Bore	J Distance Thru'
152,40	8	398,25	423,72	203,2	101,6	101,6
"	10	493,17	535,00	204,00	95,00	110,0

Sprockets in alternative materials and number of teeth can be supplied to order.